

# Cilindros Serie 40

Doble efecto, amortiguados, magnéticos  
 ø160 - 200 - 250 - 320 mm

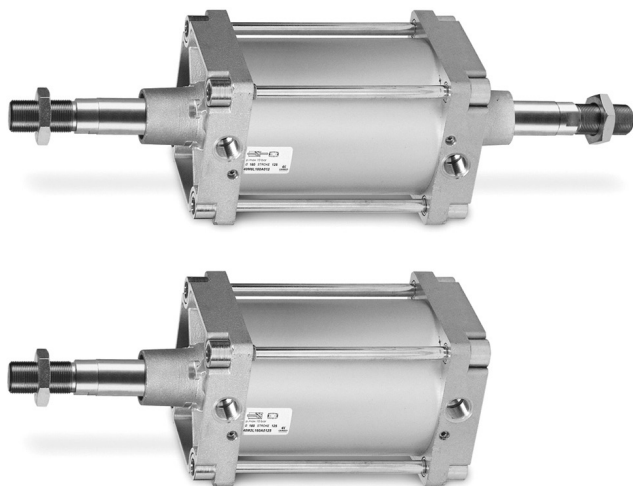

- » Conforme a la norma ISO 15552 y con las previas DIN/ISO 6431 - VDMA 24562
- » Amortiguación neumática regulable
- » Vástago en acero inox rolado (Ø 160 - 200 mm)
- » Vástago en acero inox cromado (Ø 250 - 320 mm)
- » Anillo limpiador del vástago en latón

Los cilindros de la Serie 40 de Ø 160, 200, 250 y 320 han sido realizados respetando las dimensiones de la norma ISO 15552 y de las previas ISO 6431 VDMA 24562. En el pistón de estos cilindros está alojado un imán permanente que permite, mediante interruptores de proximidad dispuestos a lo largo del eje de desplazamiento, la emisión de señales eléctricas que indican la posición del mismo.

Esta serie de cilindros se suministra normalmente con amortiguadores de fin de carrera regulables por medio de un tornillo alojado en el cabezal. A fin de reducir el ruido provocado por el impacto del pistón contra el cabezal, estos cilindros van equipados también con un amortiguador mecánico.

## CARACTERÍSTICAS GENERALES

Tipo de construcción	de tirantes
Funcionamiento	doble efecto
Materiales	cabezales y pistón en AL, vástago en acero inox AISI 420B rolado (Ø 160, 200 mm) o en acero inox cromado (Ø 250 y 320), tuerca vástago en acero zincado, camisa en aluminio anodizado, tirantes y tuercas tirantes en acero zincado, juntas vástago, pistón y amortiguación en NBR-PU anillo limpiador del vástago en latón
Montaje	Brida delantera - brida trasera - pies - basculante delantero o trasero - basculante anterior y posterior
Carreras min - max	10 ÷ 2500 mm
Temperatura de trabajo	0°C ÷ 80°C (con aire seco - 20°C)
Presión de trabajo	1 ÷ 10 bar
Velocidad	10 ÷ 500 mm/sec (sin carga)
Fluido	aire filtrado, sin lubricación. En el caso de usar aire lubricado recomendamos utilizar aceite ISOVG32 y de no interrumpir nunca la lubricación.

**TABLA DE CARRERAS ESTÁNDAR PARA CILINDROS SERIE 40**

■ = doble efecto

CARRERAS ESTÁNDAR														
Ø	25	50	75	80	100	125	150	160	200	250	300	320	400	500
160		■		■	■		■		■		■		■	■
200		■			■				■		■			
250		■			■				■		■			
320		■			■				■		■			

**EJEMPLO DE CODIFICACIÓN**

<b>40</b>	<b>M</b>	<b>2</b>	<b>L</b>	<b>160</b>	<b>A</b>	<b>0200</b>	
<b>40</b>	SERIE						
<b>M</b>	VERSIÓN: M = estándar, magnético.						
<b>2</b>	FUNCIONAMIENTO: 2 = doble efecto amortiguado - frontal + trasero 3 = doble efecto no amortiguado 4 = doble efecto amortiguado - trasero 5 = doble efecto amortiguado - frontal 6 = doble efecto vástago pasante amortiguado 8 = doble efecto, vástago pasante, sin amortiguación					SÍMBOLOS NEUMÁTICOS CD09 CD08 CD10 CD11 CD13 CD12	
<b>L</b>	CARACTERÍSTICAS MATERIALES: L = ver características generales en la página 1/1.10.01 T = tirantes inox AISI 420B - tuercas tirantes inox AISI 303 C = vástago inox AISI 303 rolado - tuerca vástago inox AISI 304 U = vástago inox AISI 303 rolado - tuerca vástago inox AISI 304 - tirantes inox AISI 420B - tuercas tirantes inox AISI 303 W = vástago inox AISI 304 rolado - tuerca vástago inox AISI 304 - tirantes inox AISI 420B - tuercas tirantes inox AISI 303 NB = vástago de los cilindros 250 y 320 mm en acero C40 cromado						
<b>160</b>	DIÁMETRO: 160 = 160 mm - 200 = 200 mm - 250 = 250 mm - 320 = 320 mm						
<b>A</b>	TIPO CONSTRUCTIVO: A = estándar F = cilindro con basculante intermedio						
<b>0200</b>	CARRERAS (ver tabla) = estándar V = junta vástago FKM W = todas las juntas en FKM + 130°C C = barnizado PU. Color: Gris G = con anillo limpiador vástago en latón (vástago inox AISI 420B cromado, junta vástago NBR) [ Ø 250 y 320 excluidos ] ( _ _ ) = vástago prolongado de _ _ _ mm Notas: Para la versión C, disponible bajo pedido, se ruega contacten nuestros técnicos. Las versiones W y C están disponibles sólo para los diámetros 160 y 200.						

**SÍMBOLOS NEUMÁTICOS**

Abajo están ilustrados los símbolos neumáticos indicados en el EJEMPLO DE CODIFICACIÓN.

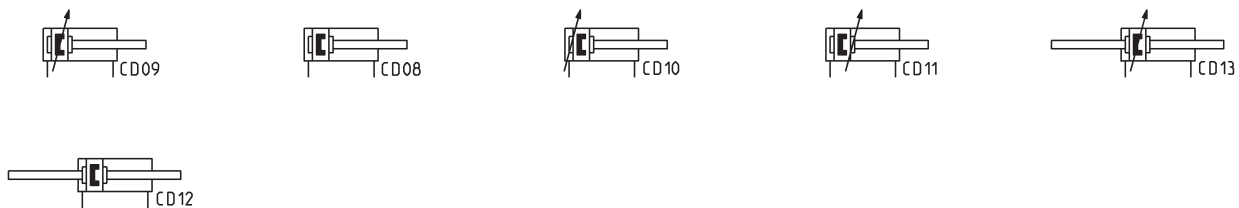

**ACCESORIOS PARA CILINDROS SERIE 40**

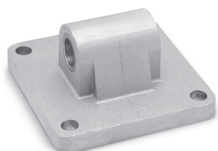

Basculante macho trasero Mod. L



Accesorio autoalineable Mod. GK



Perno Mod. S

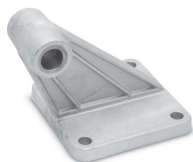

Amarre con basculante trasero en 90° Mod. ZS



Soporte para basculante int. Mod. BF



Horquilla Mod. G

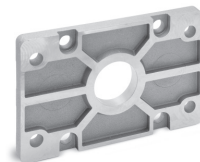

Brida rectangular trasera o delantera Mod. D-E



Basculante intermedio Mod. F



Amarre con patas Mod. B



Horquilla esférica Mod. GA

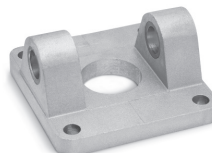

Basculante hembra Mod. C-H



Tuerca para vástago Mod. U

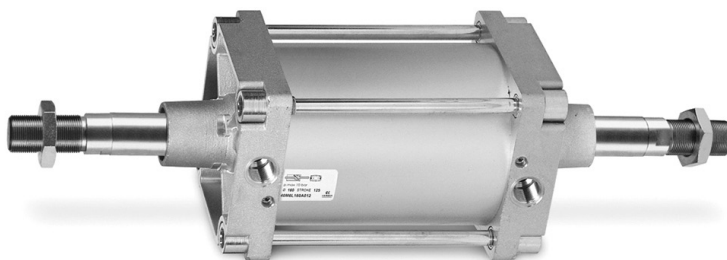

Todos los accesorios se suministran en manera separada al cilindro, excepto la tuerca vástago Mod. U. Por los sensores y abrazadera para sostener el sensor ver sección 1/9.

**Cilindros Serie 40**



+ = sumar la carrera

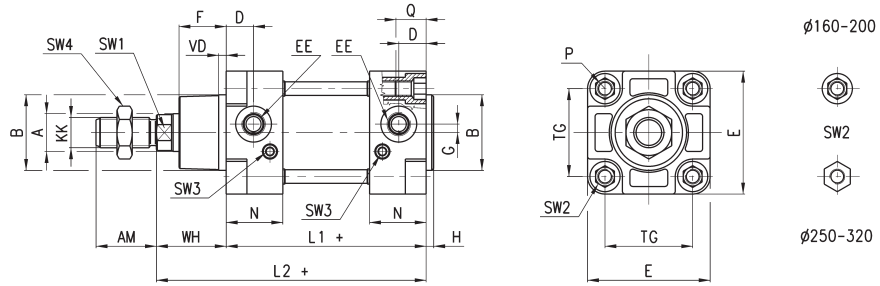

**DIMENSIONES**

$\varnothing$	A	KK	B	D	G	F	AM	H	EE	WH	L1+	L2+	VD	N	P	Q	TG	E	SW1	SW2	SW3	SW4	Carrera de amortiguación delantera/trasera
160	40	M36x2	65	25	12	53.5	72	6	G3/4	80	180	260	6	45	M16	26	140	176	36	17	4	55	29 / 36
200	40	M36x2	75	25	12	63.5	72	6	G3/4	95	180	275	6	45	M16	26	175	216	36	17	4	55	44 / 42
250	50	M42x2	90	31	12	67	84	10	G1	105	200	305	10	53	M20	30	220	270	46	36	4	65	50 / 50
320	63	M48x2	110	31	12	83	96	10	G1	120	220	340	12	55,5	M24	30	270	340	55	41	-	75	56 / 56

**Cilindros Serie 40 - vástago pasante**



+ = sumar la carrera  
++ = sumar la carrera dos veces

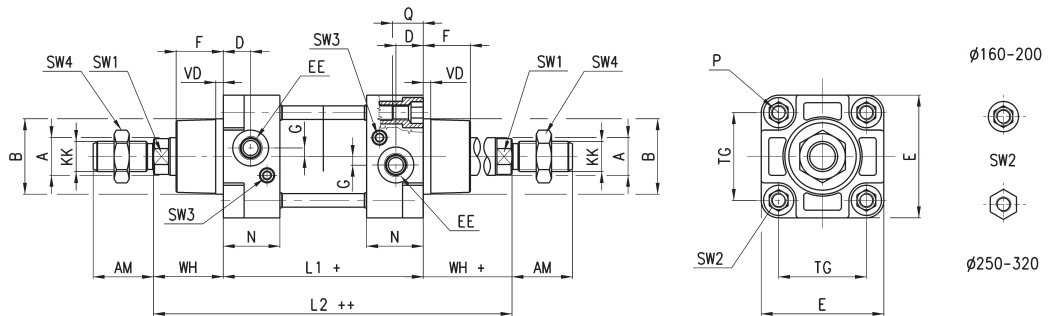

**DIMENSIONES**

$\varnothing$	A	KK	B	D	G	F	AM	EE	WH	L1+	L2++	VD	N	P	Q	TG	E	SW1	SW2	SW3	SW4	Carrera de amortiguación delantera/trasera
160	40	M36x2	65	25	12	53.5	72	G3/4	80	180	340	6	45	M16	26	140	176	36	17	4	55	29 / 36
200	40	M36x2	75	25	12	63.5	72	G3/4	95	180	370	6	45	M16	26	175	216	36	17	4	55	44 / 42
250	50	M42x2	90	31	12	67	84	G1	105	200	410	10	53	M20	30	220	270	46	36	4	65	50 / 50
320	63	M48x2	110	31	12	83	96	G1	120	220	460	12	55,5	M24	30	270	340	55	41	-	75	56 / 56

**Cilindros Serie 40 con basculante intermedio Mod. F montado**



+ = sumar la carrera  
 + 1/2 = sumar la mitad de la carrera

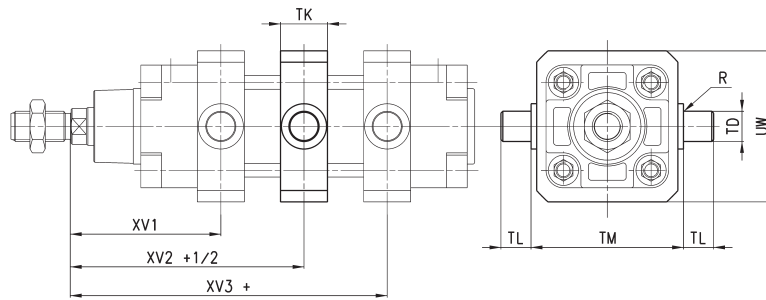

DIMENSIONES										
∅	XV1	XV2+ 1/2	XV3+	TM	TK	TD	TL	UW	R	NOTA
160	145	170	195	200	40	32	32	190	2	
200	160	185	210	250	40	32	32	240	2	
250	185	205	225	320	50	40	40	300	-	montaje con 4 tirantes roscados
320	210.5	230	249.5	400	70	50	50	400	-	montaje con 4 tirantes roscados

CILINDROS SERIE 40

### Amarre con patas Mod. B



El suministro incluye:  
N° 2 patas en acero barnizado negro  
N° 4 tornillos zincadas blancas

Para los Ø 250 y 320 zincadura blanca

+ = sumar la carrera

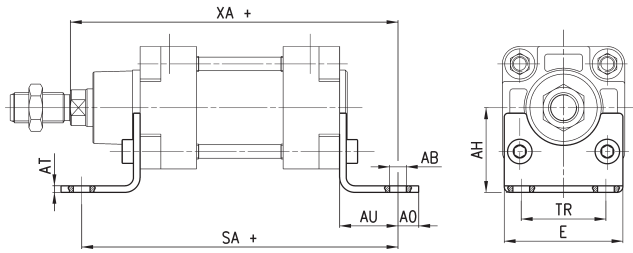

DIMENSIONES										
Mod.	Ø	AT	SA+	XA+	TR	E	AB	AH	AO	AU
B-41-160	160	10	300	320	115	175	18.5	115	25	60
B-41-200	200	12	320	345	135	238	24	135	35	70
B-41-250	250	14	350	380	165	270	26	165	25	75
B-41-320	320	20	390	425	200	353	35	200	45	85

### Montaje - brida rectangular frontal y trasera Mod. D-E

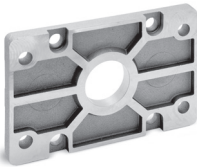

El suministro incluye:  
N° 1 brida  
N° 4 tornillos

+ = sumar la carrera

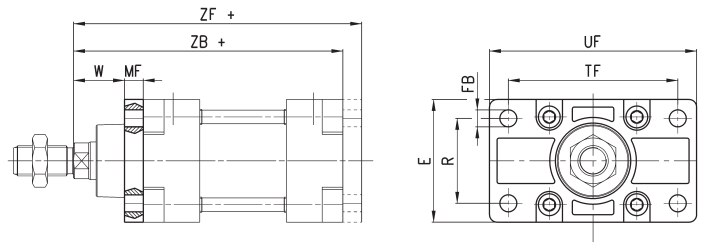

DIMENSIONES											
Mod.	Ø	W	MF	ZB+	TF	R	UF	E	ØFB	ZF+	Material
D-E-41-160	160	60	20	260	230	115	276	175	18	280	aluminio
D-E-41-200	200	70	25	275	270	135	312	215	22	300	aluminio
D-E-41-250	250	80	25	305	330	165	400	285	26	330	acero zincado
D-E-41-320	320	90	30	340	400	200	470	334	33	370	acero inoxidable 304

### Montaje - basculante trasero o delantero Mod. C-H

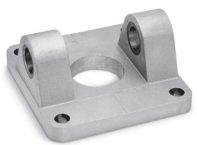

Material: aluminio.  
El suministro incluye:  
N° 1 basculante hembra  
N° 4 tornillos

+ = sumar la carrera

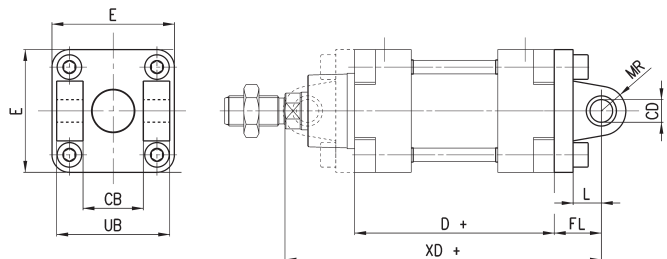

DIMENSIONES										
Mod.	Ø	ØCD	L	FL	D+	XD+	MR	E	CB	UB
C-H-41-160	160	30	35	55	180	315	30	175	90	170
C-H-41-200	200	30	35	60	180	335	30	215	90	170
C-H-41-250	250	40	45	70	200	375	40	270	110	200
C-H-41-320	320	45	50	80	220	420	45	350	120	220

### Montaje Basculante trasero macho Mod. L

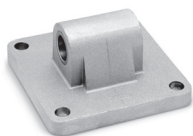

El suministro incluye:  
 N° 1 basculante macho en aluminio  
 \*  
 N° 4 tornillos  
 \* Para el Ø 320 acero barnizado negro (cataforesis)

+ = sumar la carrera

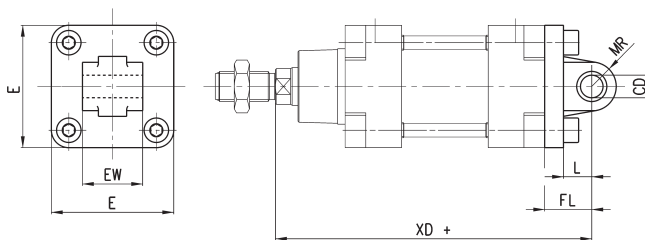

DIMENSIONES								
Mod.	Ø	ØCD	L	FL	XD+	MR	E	EW
L-41-160	160	30	35	55	315	30	175	90
L-41-200	200	30	35	60	335	30	215	90
L-41-250	250	40	45	70	375	40	270	110
L-41-320	320	45	50	80	420	45	350	110

### Montaje con basculante intermedio Mod. F



Material:  
 - acero zincado (Ø 160, 200)  
 - hierro fundido pintado (Ø 250, 320)

+ = sumar la carrera

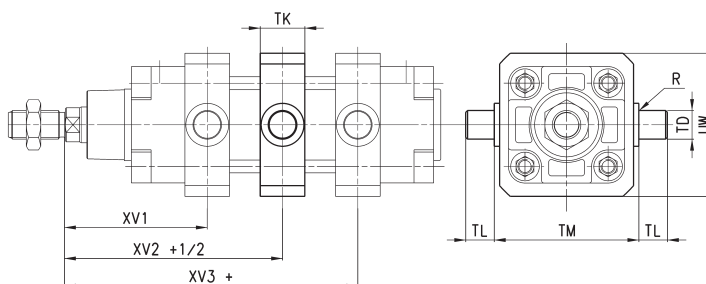

DIMENSIONES											
Mod.	Ø	XV1	XV + 1/2	XV3 +	TM	TK	ØTD	TL	UW	R	NOTA
F-160	160	145	170	195	200	40	32	32	190	2	
F-200	200	160	185	210	250	40	32	32	240	2	
F-250	250	185	205	225	320	50	40	40	296	-	montaje con 4 tirantes roscados
F-320	320	210,5	230	249,5	400	70	50	50	400	-	montaje con 4 tirantes roscados

### Montaje con basculante combinado a 90° Mod. ZS\*

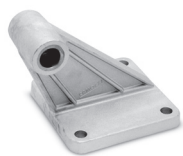

\* No según normas.  
 El suministro incluye 1 basculante de 45° en aluminio

+ = sumar la carrera

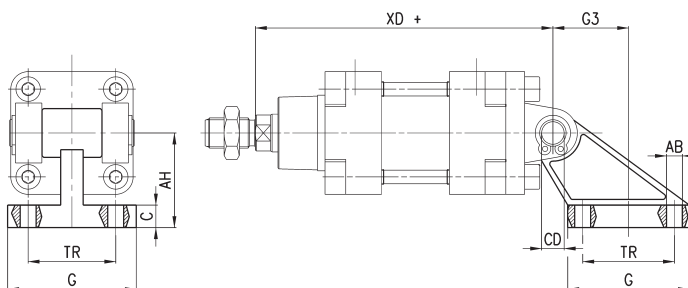

DIMENSIONES									
Mod.	Ø	TR	ØAB	AH	C	G	ØCD	XD +	G3
ZS-160	160	140	18	140	20	180	30	315	105
ZS-200	200	175	18	140	25	220	30	335	125

### Combinación de accesorios Mod. C+L+S

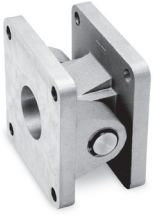

+ = sumar la carrera

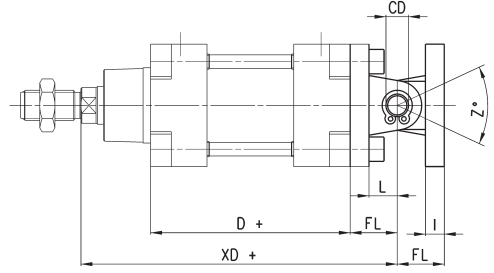
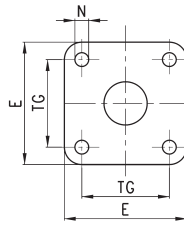

DIMENSIONES											
Mod.	∅	E	TG	∅N	D+	XD+	∅CD	L	FL	I	Z° (max)
C+L+S	160	175	140	17	180	315	30	35	55	20	25
C+L+S	200	215	175	17	180	335	30	35	60	25	20
C+L+S	250	270	220	22	200	375	40	45	70	25	33
C+L+S	320	350	270	30	220	420	40	50	80	30	30

### Soporte para basculante int. Mod. BF

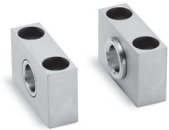

El suministro incluye 2 soportes en aluminio.

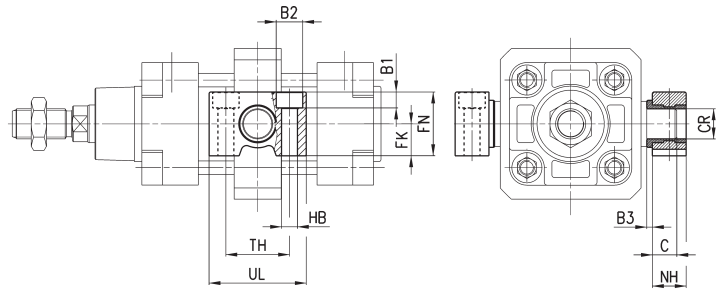

DIMENSIONES												
Mod.	∅	∅CR	NH	C	B3	TH	UL	FK	FN	B1	∅B2	∅HB
BF-160-200	160-200	32	35	17,5	4	60	92	30	60	16	26	18

### Horquilla Mod. G

ISO 8140

Material: acero zincado.

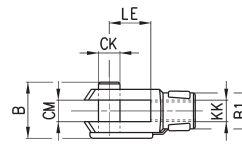
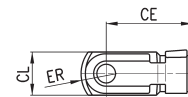
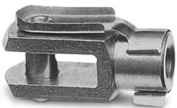

DIMENSIONES										
Mod.	∅	∅CK	LE	CM	CL	ER	CE	KK	B	∅B1
G-160-200	160-200	35	72	35	70	44	144	M36X2	92	60
G-250	250	40	84	40	85	-	168	M42x2	96	70
G-320	320	50	96	50	90	73	192	M48x2	120	80



### Horquilla esférica para vástago Mod. GA

ISO 8139

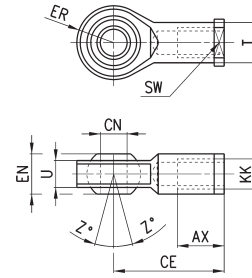

DIMENSIONES											
Mod.	∅	∅CN	U	EN	ER	AX	CE	KK	∅T	Z	SW
GA-160-200	160-200	35	28	43	40	56	125	M36x2	46	6	50
GA-250	250	40	33	49	-	60	142	M42x2	55	17	55
GA-320	320	50	45	60	58.5	65	160	M48x2	65	12	65

### Axe Mod. S

El suministro incluye:  
N° 1 perno  
N° 2 Seeger en acero

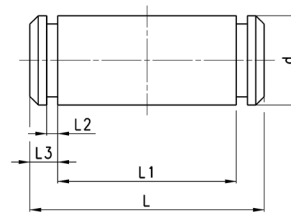

DIMENSIONES							
Mod.	∅	d	L	L1	L2	L3	
S-160-200	160-200	30	180.5	172	1.6	4.25	acero inoxidable 303
S-250	250	40	210	202	1.85	4.5	acero zincado
S-320	320	45	236	222	1.85	7	acero zincado

### Tuerca para vástago Mod. U

ISO 4035.  
Material: acero zincado.

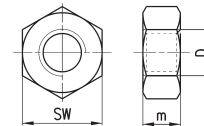

DIMENSIONES				
Mod.	∅	D	m	SW
U-160-200	160-200	M36x2	14	55
U-250	250	M42x2	16	65
U-320	320	M48x2	24	75

### Accesorio autoalineable Mod. GK

Material: acero zincado.

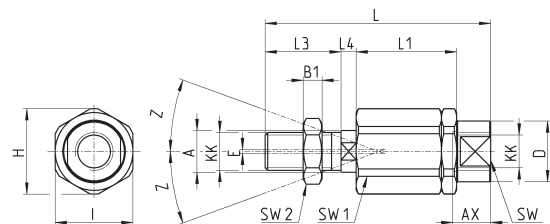

DIMENSIONES																	
Mod.	∅	KK	L	L1	L3	L4	∅A	∅D	H	I	SW	SW1	SW2	B1	AX	Z	E
GK-160-200	160-200	M36x2	190	77	72	15.5	39	57	75	70	54	32	55	14	68	4	2