

Valve islands, Size 4, Multipole and Fieldbus Series D



Fieldbus connection with the most common communication protocols PROFIBUS-DP, PROFINET, CANopen, EtherNET/IP, EtherCAT and IO-Link



Multipole connection with 25 or 44 pins

Valve functions: 2x3/2; 5/2; 5/3 CC, CO, CP

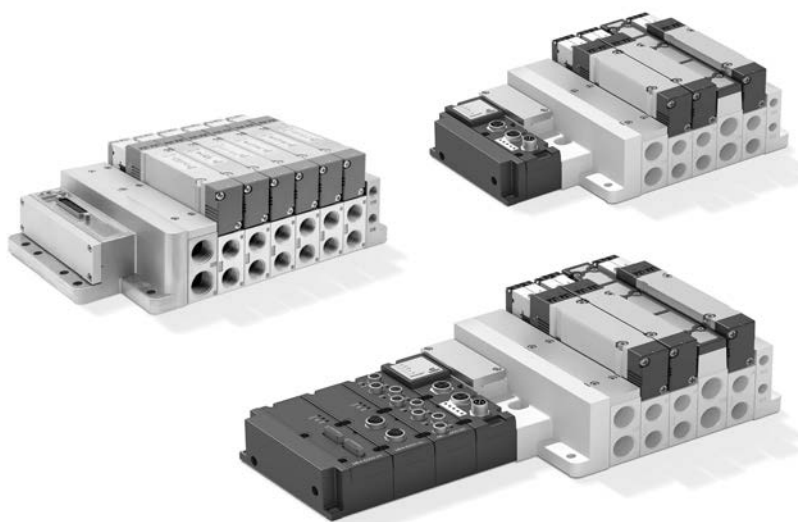

Thanks to the large range of options available, the Series D valve island represents an excellent solution for all those applications that require pneumatic and electrical functions in restricted spaces.

The different electrical connection possibilities allow to create Islands with a high number of valve positions and different pressure zones. Moreover, the fieldbus version can manage both digital and analog electric input and output signals.

- » Valve size 25 mm
- » Compact design
- » Individual modular subbases in metal
- » Highly expandable electrically and pneumatically
- » Flexibility in connecting and exchanging I/O modules
- » COILVISION technology to monitor performance parameters
- » Same subbase for monostable and bistable valves
- » Possibility to transmit operational data through WLAN
- » Blinking LEDs indicating different types of operating faults

Small dimensions, high flows, subbases with individual pneumatic and electric modules, an easy subbase connection system, constant diagnosis and monitoring of performance parameters make this series a particularly innovative product.

One of the features of this series is the monitoring function regarding the correct operating of the solenoid valve.

The electronics installed both in the subbase and in the Sub-D and multi-serial connection module, enables to constantly monitor the efficiency of the driving coil of the solenoid valve.

Possible variations with respect to the ideal operating conditions, for example a higher power consumption, variation in response times and an increased temperature are indicated through different ways of blinking by the LED on the solenoid valve and by an electric alert signal that is sent to the PLC through the Sub-D module connecting cable or, in case of the multi-serial connection module, directly through the communication protocol.

Manual, instruction sheet and configurator are available on the site <http://catalogue.camozzi.com> or by means of the QR code on the product's label.

GENERAL DATA

PNEUMATIC SECTION	
Valve construction	spool with seals
Valve functions	5/2 monostable and bistable 5/3 CC, CO, CP 2x3/2 NC 2x3/2 NO 1x3/2 NC + 1x3/2 NO
Materials	spool: AL spool seals: HNBR other seals: NBR body: AL end caps: polymer individual subbase: AL
Connections	outlet 2 and 4, threaded G 3/8 supply 1: G 1/2 supply 12/14: G 1/8 exhaust 3 and 5: G 1/2 or integrated silencer exhaust 82/84: G 1/8
Temperature	0 ÷ 50°C
Air characteristics	compressed, filtered and non-lubricated air in class [7:4:4] according to ISO 8573-1:2010. In case lubrication should be necessary, only use oils with a maximum viscosity of 32 Cst and the version with external servo-pilot supply. The air quality of the servo-pilot supply must be of class [7:4:4] according to ISO 8573-1:2010 (do not lubricate).
Valve sizes	4 = 25 mm
Operating pressure	-0,9 ÷ 10 bar (-0.7 -10 bar for 2x3/2 versions)
Internal pilot pressure	2,5 ÷ 7 bar 4,5 ÷ 7 bar (with operating pressure exceeding 6 bar for the version 2x3/2)
External pilot pressure	SEE GRAPHS
Flow rate	2000 Nl/min
Mounting position	any position
Protection class	IP 65
ELECTRICAL SECTION MULTIPOLE VERSION	
Type of Sub-D connector	25 or 44 pins
Max. absorption	0.8 A (with Sub-D connector 25 pins) 1,5 A (with Sub-D connector 44 pins)
Supply voltage	24 V DC +/- 10%
Max. number of coils to operate	22 on 11 valve positions (with Sub-D connector 25 pins) 38 on 19 valve positions (with Sub-D connector 44 pins)
Signalling LED	Multipole: green LED - presence of power red LED - anomaly Valve: yellow LED - presence of power blinking yellow LED - operating fault
ELCTRICAL SECTION FIELDBUS VERSION	
General data	see Multi-serial Modules section on the next pages
Max. absorption	2.5 A
Supply voltage	24 V DC +/-10% logic supply 24 V DC +/-10% power supply
Max. number of coils to operate	128 on 64 valve positions
Max. number of digital inputs	128
Max. number of analog inputs	16
Max. number of digital outputs	128
Max. number of analog outputs	16
IO-Link version	
Max n° of coils to operate	64 on 32 valve positions
Input and Output	No
Type of port	Class B
IODD Configuration file	up to 12, 24 or 32 valve positions per island
(The IO-Link module on the valve island is auto-configured to operate with the right IODD)	
More information can be found at http://catalogue.camozzi.com Series D "Instructions for use and maintenance"	

INTERMEDIATE SUBBASES

Intermediate subbases with a diaphragm or additional supply function allow to create diversified pressure and/or exhaust zones, add an incoming air flow and increase the exhaust flow. Furthermore there are subbases available that, besides the aforementioned functions, can interrupt the pneumatic actuation to the coils. The intermediate subbases do not need to be calculated in the number of valve positions.

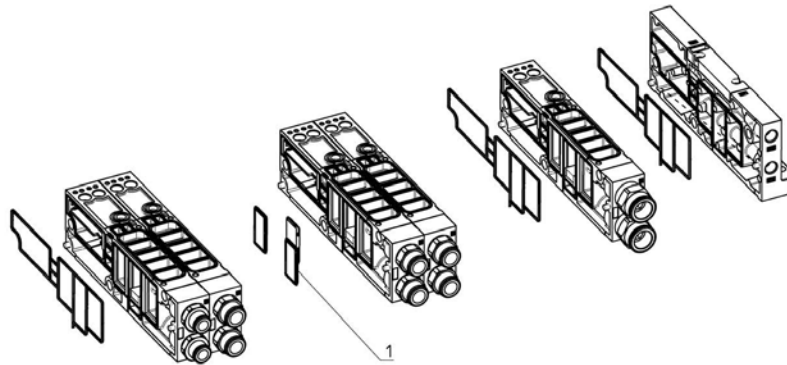

INITIAL/INTERMEDIATE SUBBASES

These intermediate subbases can be positioned as desired with the valve subbases and enable to connect a supply and exhaust source. One of these must always be present within the valve island. Available in three versions, they provide the possibility to exhaust the air by means of a silencer placed in the upper part or on the front, or by means of a connection in order to convey the exhaust to the desired direction. These subbases do not use electric signals and are not to be considered when counting the positions. After inserting the seals (1) on the valve subbases, you need to insert one of these subbases (2).

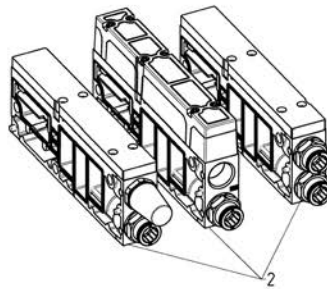

SERVOPILOT

The right terminal includes the device to select the servopilot, either internal or external, which can be selected by rotating the device. By applying the right servopilot pressure to connection 12/14, it is possible to use the solenoid valves with different pressures compared to the standard range and with vacuum. By means of separator seals it is also possible to section the island, creating a combination of pressure and vacuum zones.

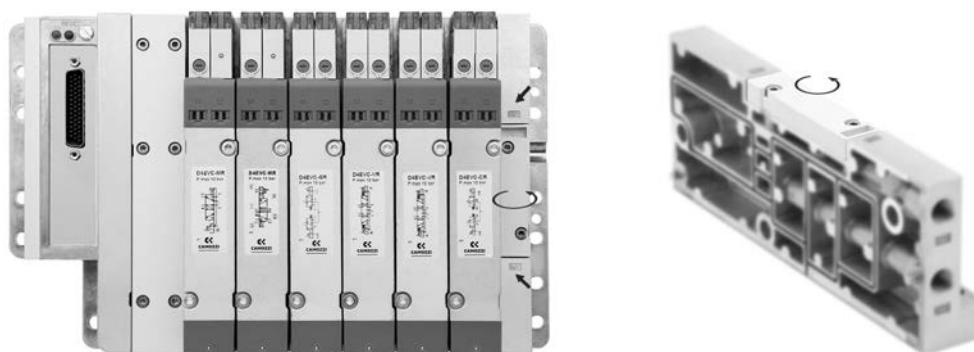

CONFIGURATOR

The island configuration is of minimum three positions including the possible base for additional supply and/or exhaust. The maximum number of positions depends on the selected type of electrical connection. To correctly compose the commercial code and to download drawings, please use the configurator present at <http://catalogue.camozzi.com> in the sections "Configurators" or "Camozzi Partcommunity".

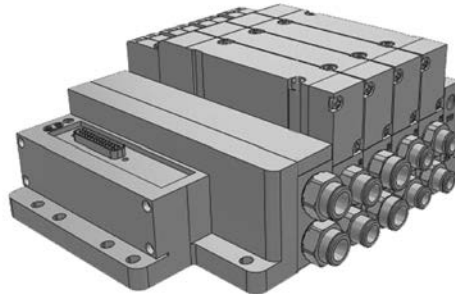

MULTIPOLE VERSION

The multipole version can be connected quickly and safely through the connecting cable with angled outlet of 25 or 44 pins to the electric Sub-D connector integrated in the island. The single modularity of the subbases allows to create islands with up to a maximum of 11 or 19 valve positions according to the type of connecting cable used.



FIELDBUS and IO-LINK VERSION

The new CX4 fieldbus module integrated in the Series D valve island enables to interface with the most common fieldbus protocols. Besides managing the pneumatic part (the same as the Multipole version) different kinds of electric modules can be managed. With this configuration it is possible to enlarge the pneumatic part up to a maximum of 64 valve positions with double command and the electric part up to 128 digital inputs and 128 digital outputs, besides 16 analog inputs and 16 analog outputs. Besides the standard voltage and current versions, the analog modules are also available in 2-channel Bridge, RTD and TC versions.

Also in the IO-Link version, the interface module is part of the Series CX4.

In this configuration, the I/O Modules cannot be integrated in the island, a maximum of 64 coils can be managed on 32 valve positions.

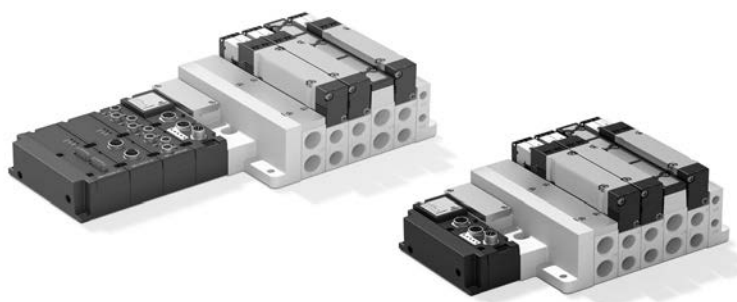

ELECTRICAL MODULE

The electric modules are composed of two parts: the base to connect the different modules, which is the same for all types, and different covers on which the connectors are positioned. This solution enables to easily change the connection points with the sensors or functions of the machine. Also the electric modules, like the subbases in the pneumatic part, can be added or removed thanks to the modular connection system.

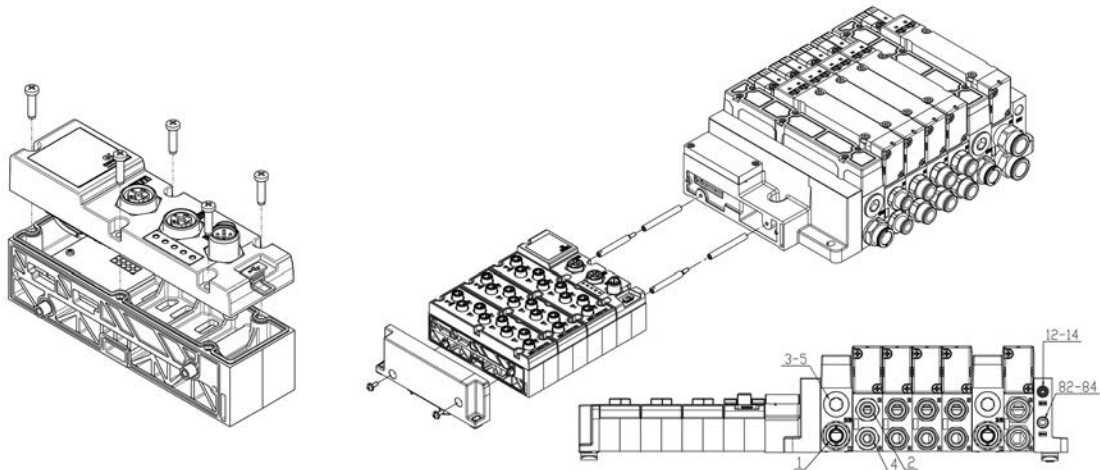

COILVISION

This is a standard function in all our valve islands with Multipole and Serial connection. Its purpose is to monitor the proper function of each solenoid valve individually, particularly the solenoid. The electronics installed in the subbase allows to constantly monitor the efficiency of the driving coil of the solenoid valve. Possible variations with respect to the ideal operating conditions, like for example a higher power consumption, different response times or an increased temperature, are reported by means of a blinking yellow LED of the interested solenoid. Besides the blinking of this LED, also a general red LED blinks located on the Sub-D module. These indications are combined with an alert message sent to the PLC. By selecting code W from the "Interface" menu of the encryption code, besides the described signals, it is possible to gather all operational data of the islands and send them through WLAN to the corporate net or onto the Cloud to be analysed.

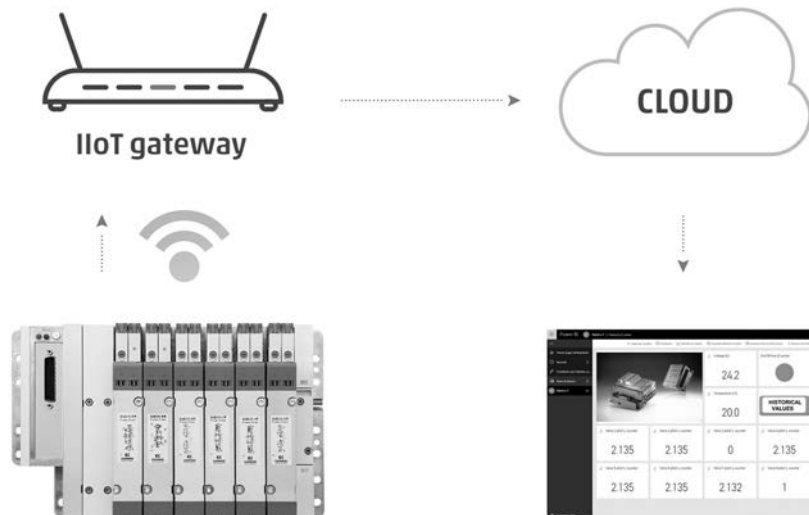

CODING EXAMPLE - MULTIPOLE VERSION

DM C 4 M W R A - 03R - XHCDQ2DXHE - 2MB2C - E R

DM	MODULAR ISLAND
C	VALVE C = VC Model
4	SIZE 4 = 25 mm
M	ELECTRICAL CONNECTION M = Multipole 25 pin PNP Q = Multipole 44 pin PNP
W	INTERFACE O = without interface W = WLAN
R	MANUAL OVERRIDE P = push button R = with push and turn device
A	SERVO-PILOT SUPPLY A = internal B = external C = external with fitting (S6510 6-1/8) and threaded silencer (2931 1/8) D = internal with threaded silencer (2931 1/8)
03R	CONNECTOR 0 = without connector CONNECTOR R WITH CABLE 03R = 3 mt 05R = 5 mt 10R = 10 mt 15R = 15 mt 20R = 20 mt 25R = 25 mt
XHCDQ2DXHE	SUBBASES K = threaded subbase C = with fittings for tube Ø8 (S6510 8-3/8) D = with fittings for tube Ø10 (S6510 10-3/8) E = with fittings for tube Ø12 (S6510 12-3/8) F = with fittings for tube Ø14 (S6510 14-3/8) SEALS Q = seal on channels 1, 3, 5 R = seal on channel 1 V = seal on channels 3 and 5 INITIAL SUBBASE/INTERMEDIATE:* X = supply (1) and exhausts (3, 5) XS = supply (1) and exhausts (3, 5) with threaded silencer (2931 1/2) XH = supply (1) and exhausts (3, 5) with silencer * These subbases use the connection described in the Terminal Plates menu
2MB2C	VALVES M = 5/2 monostable B = 5/2 bistable C = 2x3/2 NC A = 2x3/2 NO G = 2x3/2 (NC+NO) V = 5/3 CC K = 5/3 CO N = 5/3 CP L = free position W = position without valve
E	TERMINAL PLATES CONNECTIONS K = threaded G 1/2 D = with fittings for tube Ø10 (S6510 10-1/2) E = with fittings for tube Ø12 (S6510 12-1/2) F = with fittings for tube Ø14 (S6510 14-1/2) G = with fittings for tube Ø16 (S6510 16-1/2)
R	FIXING TYPE = direct R = DIN rail

SERIES D4 VALVE ISLANDS

The choice of the fitting made in the Terminal Plates section is also valid for the initial subbase/intermediate

CODING MULTIPOLE VERSION

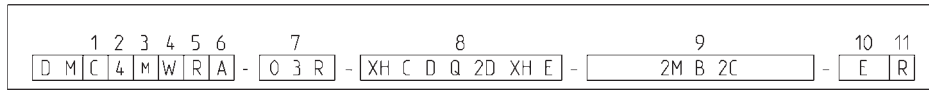
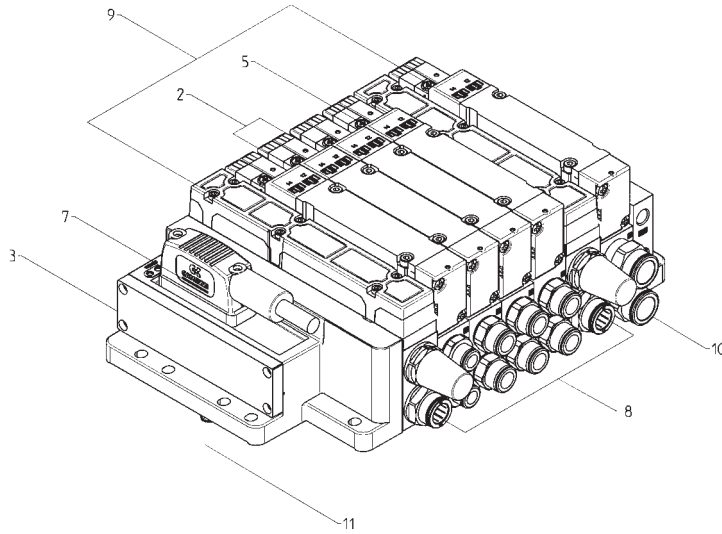

(1)	VALVE MODEL VC	(2)	SIZE	(3)	ELECTRICAL CONNECTION	(4)	INTERFACE	(5)	MANUAL OVERRIDE	(6)	SERVO-PILOT
	C		4		M		O		P		A
					Q		W		R		B
											C
											D
(7)	CONNECTION			(8)	SUBBASES	(9)	VALVES	(10)	TERMINAL PLATES CONNECTION	(11)	MOUNTING
	0				K		M		K		R
	03R				C		B		D		
	05R				D		C		E		
	10R				E		A		F		
	15R				F		G		G		
	20R				SEALS		V				
	25R				Q		K				
					R		N				
					V		L				
					INITIAL SUBBASE/INTERMEDIATE						
					X						
					XS						
					XH						

CODING EXAMPLE - FIELDBUS VERSION

DM C 4 01 W R A - 2A2Q - XHCDQ2DXHE - 2MB2C - E R

DM	MODULAR ISLAND
C	VALVE C = VC Model
4	SIZE 4 = 25 mm
01	PROTOCOL 00 = Base without Fieldbus cover* 01 = PROFIBUS 03 = CANopen 04 = Ethernet/IP 05 = Ethercat 06 = PROFINET 07 = IO-LINK (cannot be configured with input and output modules)
W	INTERFACE 0 = without interface W = WLAN
R	MANUAL OVERRIDE P = push button R = with push and turn device
A	SERVO-PILOT SUPPLY A = internal B = external C = external with fitting (6512 6-1/8) and threaded silencer (2931 1/8) D = internal with threaded silencer (2931 1/8)
2A2Q	INPUT AND OUTPUT MODULES 0 = without A = 8 Digital inputs M8 B = 16 Digital inputs, terminal block connection (Push-in) C = 2 Analog inputs (config. 0-10V,±10V,0-20mA,4-20mA,±20mA) M12 D = 2 Analog inputs (config. 0-10V,±10V,0-20mA,4-20mA,±20mA), terminal block connection (Push-in) E = 2 Inputs, BRIDGE M12 F = 2 Inputs, BRIDGE, terminal block connection (Push-in) G = 2 Inputs, RTD M12 (PT100, PT200, PT500, PT1000) H = 2 Inputs, RTD terminal block connection (Push-in) (PT100, PT200, PT500, PT1000) L = 2 Inputs, TC M12 (THERMOCOUPLES) M = 2 Inputs, TC terminal block connection (Push-in) (THERMOCOUPLES) Q = 8 Digital outputs M8 R = 16 Digital outputs, terminal block connection (Push-in) T = 2 Analog outputs (config. 0-10V,±10V,0-20mA, 4-20mA,±20mA), M12 U = 2 Analog outputs (config. 0-10V,±10V,0-20mA,4-20mA,±20mA), terminal block (Push-in) P = 8 Digital inputs (4 M12 connectors) Y = 8 Digital outputs (4 M12 connectors) W** = Closed base without I/O cover
XHCDQ2SXHE	SUBBASES K = threaded subbase C = with fittings for tube Ø8 (S6510 8-3/8) D = with fittings for tube Ø10 (S6510 10-3/8) E = with fittings for tube Ø12 (S6510 12-3/8) F = with fittings for tube Ø14 (S6510 14-3/8) SEALS Q = seal on channels 1, 3, 5 R = seal on channel 1 V = seal on channels 3 and 5 INITIAL SUBBASE/INTERMEDIATE:* X = supply (1) and exhausts (3, 5) XS = supply (1) and exhausts (3, 5) with threaded silencer (2931) XH = supply (1) and exhausts (3, 5) with silencer * These subbases use the connection described in the Terminal Plates menu
2MB2C	VALVES M = 5/2 Monostable B = 5/2 Bistable C = 2x3/2 NC A = 2x3/2 NO G = 2x3/2 (NC+NO) V = 5/3 CC K = 5/3 CO N = 5/3 CP L = Free position W = position without valve
E	TERMINAL PLATES CONNECTIONS K = threaded G 1/2 D = with fittings for tube Ø10 (S6510 10-1/2) E = with fittings for tube Ø12 (S6510 12-1/2) F = with fittings for tube Ø14 (S6510 14-1/2) G = with fittings for tube Ø16 (S6510 16-1/2)
R	FIXING TYPE = direct R = DIN rail

The choice of the fitting made in the Terminal Plates section is also valid for the initial subbase/intermediate

*With the 00 protocol, the possible interface is 0, for example: DMC4000RA-...

**The closed base without I/O cover must always be placed after the other modules if present e.g. : DMC401WRA-2A2QW...

FIELDBUS VERSION CODING

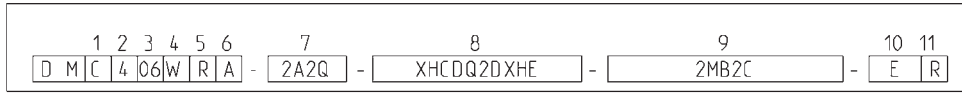
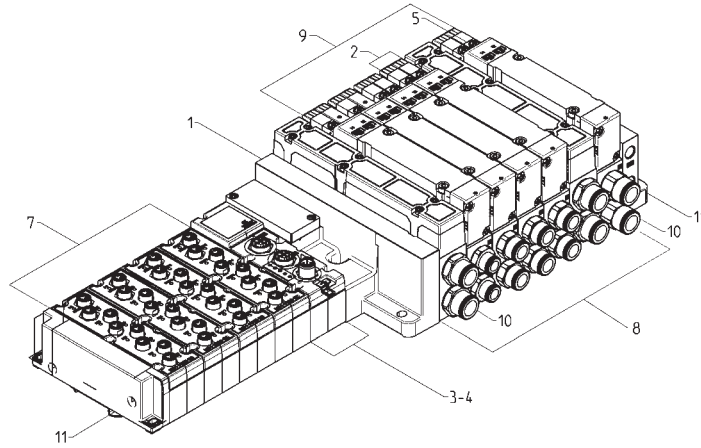

(1)	VALVES	(2)	SIZE	(3)	PROTOCOL	(4)	INTERFACE	(5)	MANUAL OVERRIDE	(6)	SERVO-PILOT
	VC		4		00		0		P		A
					01		W		R		B
					03						C
					04						D
					05						
					06						
					07						
(7)	INPUT AND OUTPUT MODULES			(8)	SUBBASES	(9)	VALVES	(10)	TERMINAL PLATES CONNECTION	(11)	FIXING
	A				K		M		K		R
	B				D		B		D		
	C				C		C		E		
	D				E		A		F		
	E				F		G		G		
	F				SEALS		V				
	G				Q		K				
	H				R		N				
	L				V		L				
	M				INITIAL SUBBASE INTERMEDIATE						
	Q				X						
	R				XS						
	W				XH						
	P										
	Y										

SERIES D4 VALVE ISLANDS

MULTIPOLE version COMPONENTS

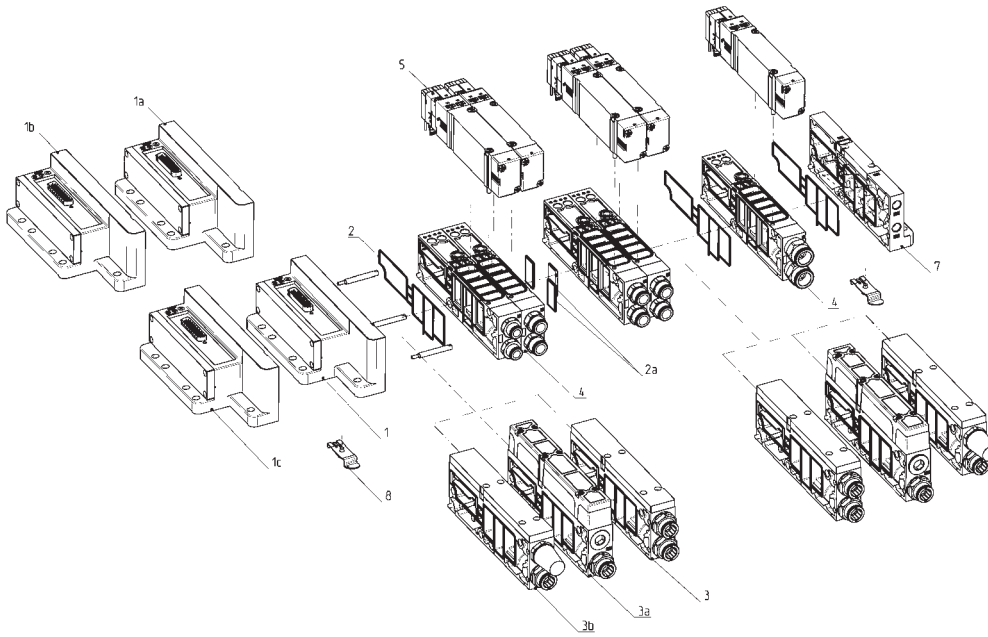

COMPONENTS	
1	Electric interface group - multipole 25 pins
1a	Electric interface group - multipole 25 pins WLAN interface
1b	Electric interface group - multipole 44 pins
1c	Electric interface group - multipole 44 pins WLAN interface
2	Interface seals
2a	Separator seals
3	Additional module to convey supply and exhaust channels
3a	Module to convey supply and to silence the exhaust channel integrated
3b	Module to convey supply and to silence the exhaust channel threaded
4	Modular subbase size 4
5	Solenoid valve size 4
7	Terminal plate
8	Mounting bracket for DIN rail

FIELDBUS version COMPONENTS

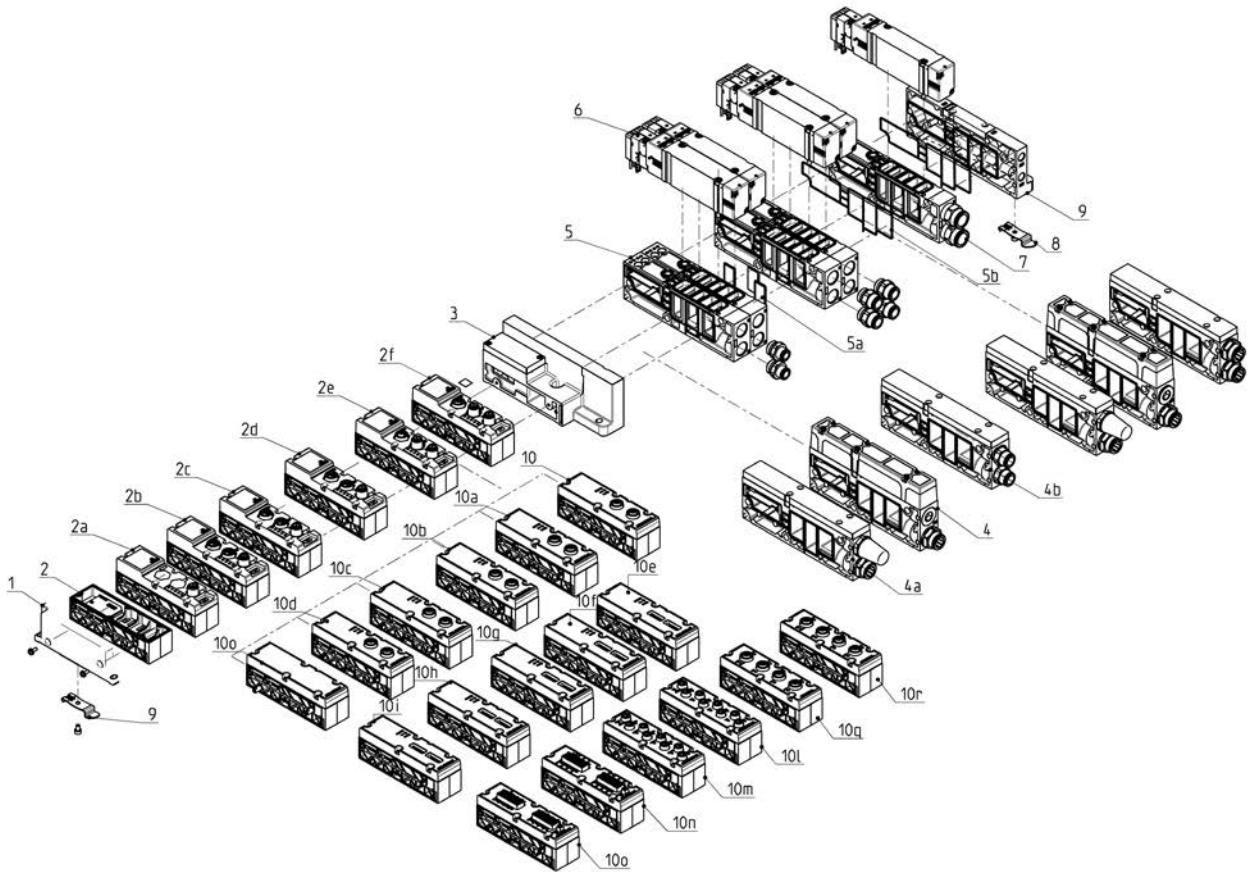

COMPONENTS			
1	Terminal module	8	Mounting bracket for DIN rail
2	Base without Fieldbus cover	9	Terminal plate
2a	IO-Link module	10	2 Analog voltage/current Inputs, M12
2b	PROFINET module	10a	2 Analog load cell Inputs, M12
2c	EtherCAT module	10b	2 Analog thermocouple Inputs, M12
2d	EtherNet/IP module	10c	2 Analog RTD Inputs, M12
2e	CANopen	10d	2 analog outputs, M12
2f	PROFIBUS module	10e	2 Analog voltage/current Inputs, terminal block
3	Fieldbus module interface	10f	2 Analog load cells Inputs, terminal block
4	Supply and exhaust module with integrated silencer	10g	2 Analog thermocouple Inputs, terminal block
4a	Supply and exhaust module with threaded silencer	10h	2 Analog RTD Inputs, terminal block
4b	Additional conveyed supply and exhaust module	10i	2 analog outputs, terminal block
5	Modular subbase size 4	10l	8 Digital Inputs
5a	Separator seal	10m	8 Digital Outputs
5b	Interface seal	10n	16 Digital Inputs
6	Solenoid valve size 4	10o	16 Digital Outputs
7	Fittings	10p	I/O module
		10q	8 Digital Inputs (4 M12 connectors)
		10r	8 Digital Outputs (4 M12 connectors)

MULTIPOLE version 25 and 44 pin DIMENSIONS

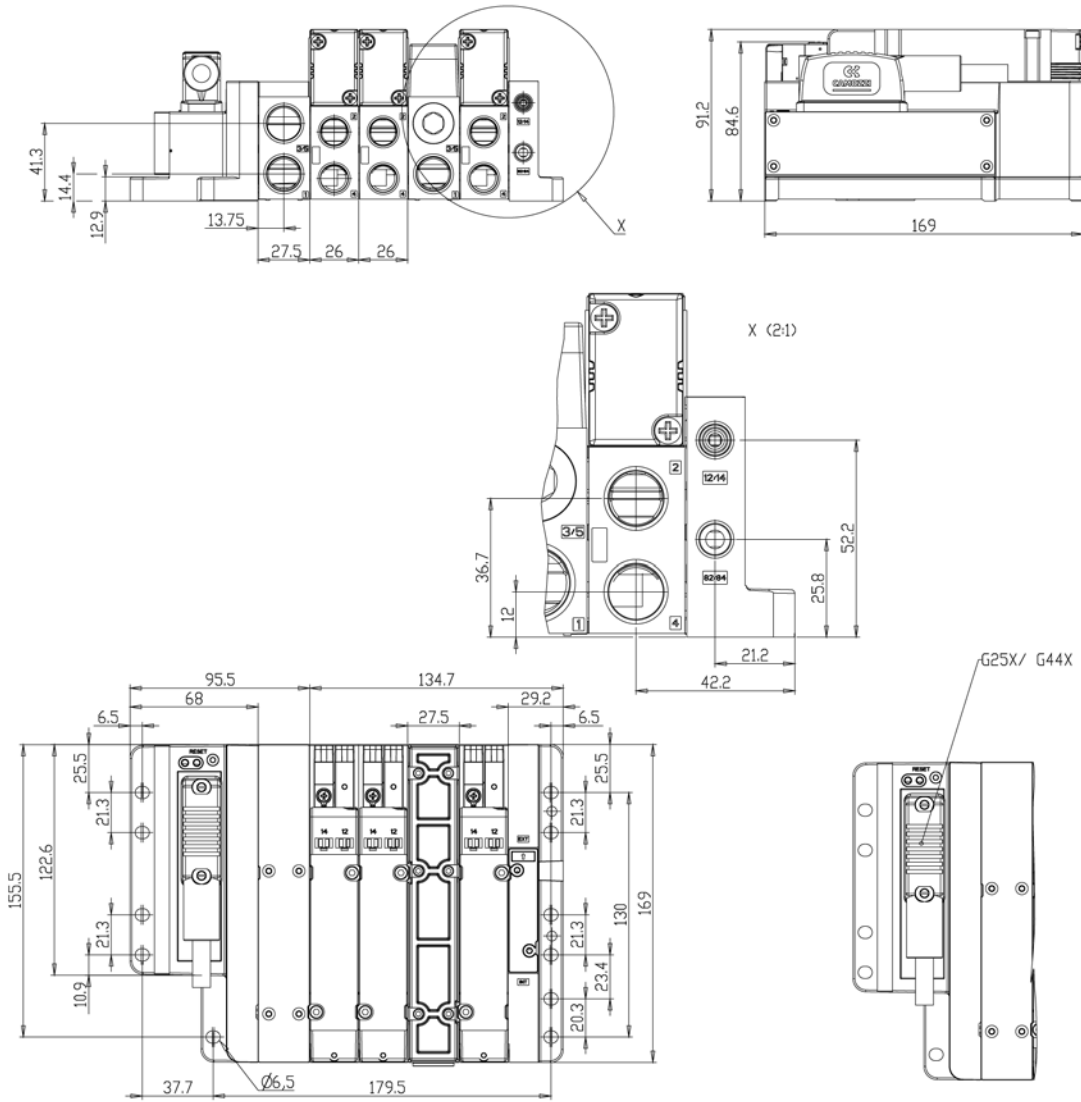

FIELDBUS version DIMENSIONS

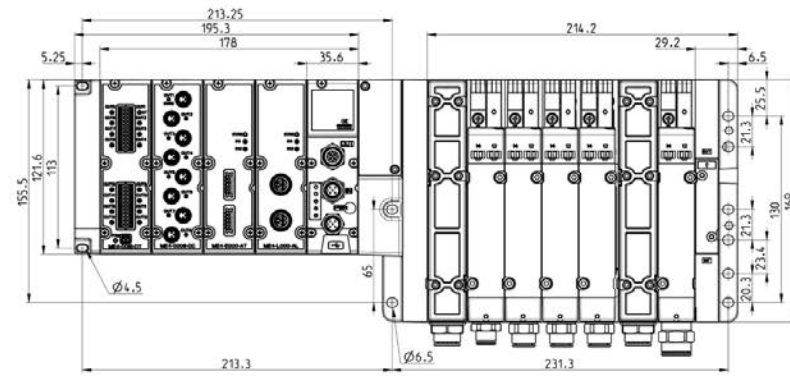
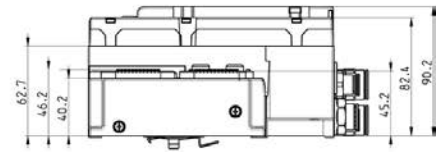
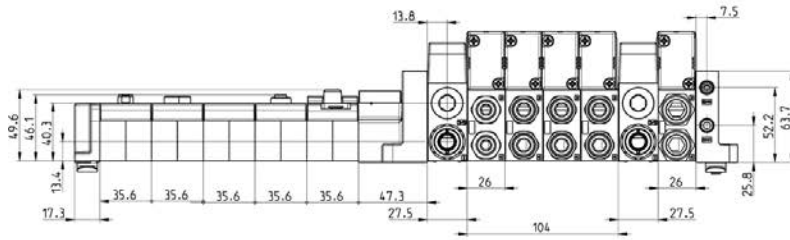

SERIES D4 VALVE ISLANDS

CODING EXAMPLE

D	4	E	VC	-	M	P
D	SERIES					
4	SIZE: 4 = 25 mm					
E	VERSION: E = solenoid valve					
VC	COMPONENT: VC = plugin valve					
M	TYPE OF SOLENOID VALVE M = 5/2 monostable B = 5/2 bistable C = 2 x 3/2 NC A = 2 x 3/2 NO G = 2 x 3/2 (NC+NO) V = 5/3 CC K = 5/3 CO N = 5/3 CP					
P	MANUAL OVERRIDE: P = push button R = with push and turn device					

AVAILABLE FUNCTION - SYMBOLS FOR SOLENOID VALVES

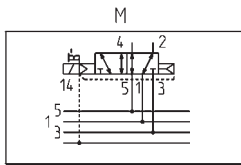

M = 5/2, Monostable

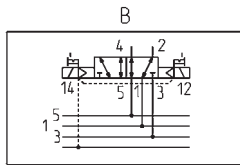

B = 5/2, Bistable

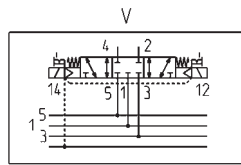

V = 5/3 Centres Closed

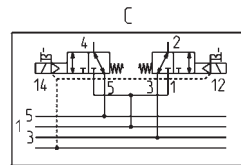

C = 2 x 3/2 NC

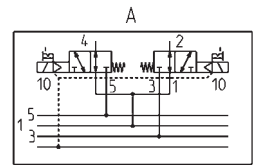

A = 2 x 3/2 NO

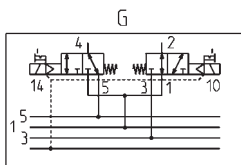

G = 1 x 3/2 NC +
1 x 3/2 NO

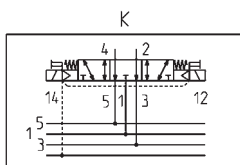

K = 5/3 CO

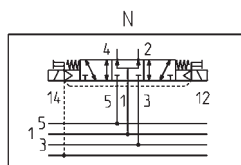

N = 5/3 CP

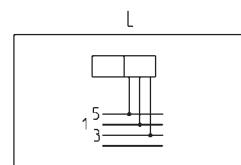

L = free position

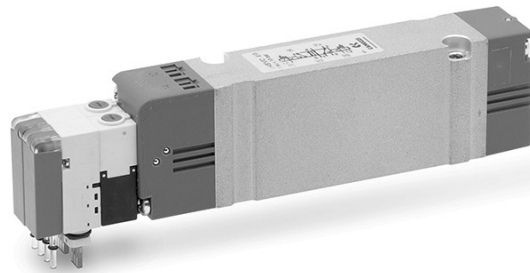
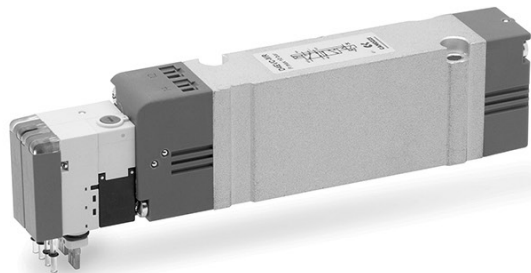

EXTERNAL PILOT PRESSURE GRAPHS

Valve model

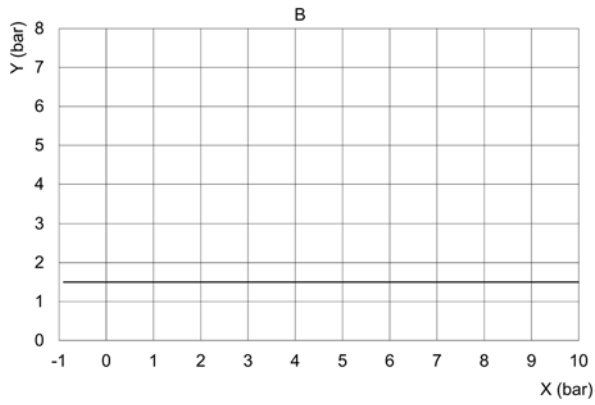

x = Supply pressure
y = Pilot pressure

Valve model

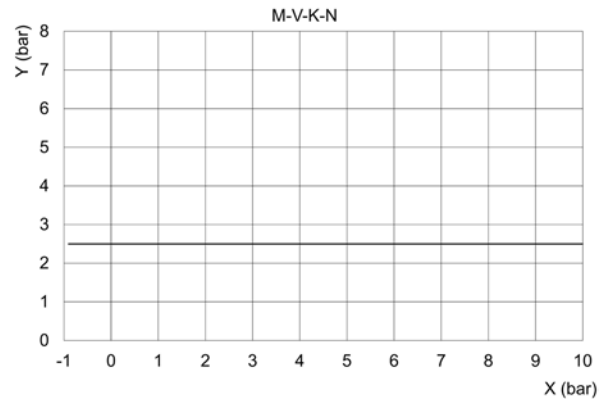

x = Supply pressure
y = Pilot pressure

Valve model

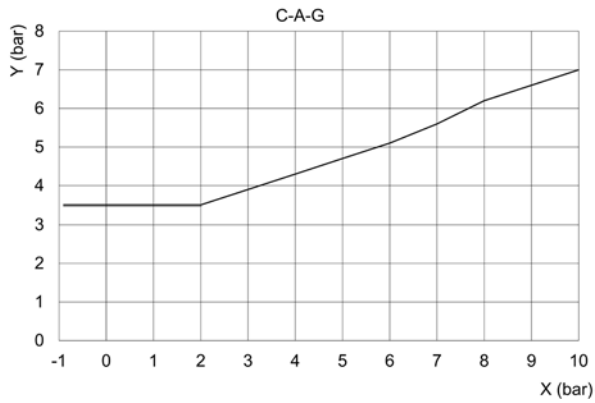

x = Supply pressure
y = Pilot pressure

Plate to cover non used valve positions

The supply includes:
1 plate
2 fixing screws



Mod.
D4EVC-L

Subbase for additional valve positions

D	AM	4	S	-	T	T
----------	-----------	----------	----------	----------	----------	----------

D	SERIES
AM	ACCESSORIES AM = modular accessories
4	SIZE 4 = 25
S	COMPONENT S = modular subbase
T	VERSION T = threaded valves subbase
T	TIE ROD = without tie rod T = with tie rod



Initial/intermediate subbase with supply and exhaust

D	AM	4	S	-	XH	-	T
----------	-----------	----------	----------	----------	-----------	----------	----------

D	SERIES
AM	ACCESSORIES AM = modular accessories
4	SIZE 4 = 25 mm
S	COMPONENT S = intermediate subbase
XH	SUBBASE FOR ADDITIONAL FLOW XC = supply (1) and additional exhaust (3,5) XS = supply (1) and exhausts (3, 5) with threaded silencer (2931) XH = supply (1) and exhaust (3,5) with integrated silencer
T	TIE ROD = without tie rod T = with tie rod



Cover plate for initial/intermediate subbase

This plate is used in case you want to change an intermediate subbase with integrated silencer into a subbase with conveyed exhaust.



Mod.
DAM40-C

Exhaust silencer for initial/intermediate subbase

This silencer is used in case you want to change an intermediate subbase with conveyed exhaust into a subbase with integrated silencer.

We advise to replace this component at least once a year.



Mod.
DAM40-H

Multipole terminal

D	AM	4	T	-	Q	0
----------	-----------	----------	----------	----------	----------	----------

D	SERIES	
AM	ACCESSORIES AM = modular accessories	
4	SIZE 4 = 25 mm	
T	COMPONENT T = electrical left terminal plate	
Q	TYPE OF TERMINAL PLATE M = multipole 25 pins Q = multipole 44 pins	
0	INTERFACE 0 = without interface W = WLAN	



Right terminal with internal/external servopilot

The supply includes:
3 fixing screws M5



Mod.
DAM40-RT

Seals to separate supply and/or exhaust channels

NB These seals are inserted on the valve subbases and need to be combined with an initial/intermediate subbase.

Description of seal assembly below.

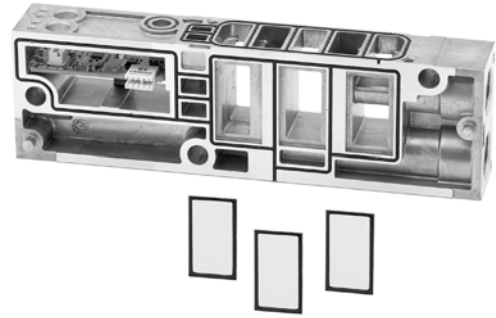

	Seals channel
DAM4D-R	1
DAM4D-V	3; 5
DAM4D-Q	1; 3; 5

Connection interface between electrical section and valves

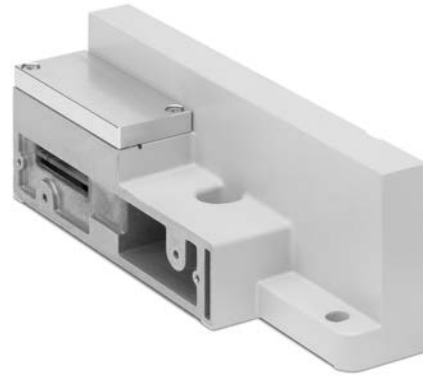

Mod.	ME4-00D4-DI
------	-------------

Closing terminal of Fieldbus electrical section

The supply includes:
1 terminal plate
2 fixing screws



Mod.	CX4AP-L
------	---------

Multi-serial modules



On this module there are three connectors, one for supply on which it is possible to separate logic supply from power supply and two connectors for the inlet and outlet of the protocol.
 A Micro-USB port enables to interface with a PC and by means of the UVIX configuration software it is possible to monitor and configure both the Multi-serial Module and the I/O Modules. Connectable on the left side.
 These can be configured as PNP or NPN for the Digital Inputs, while for the Analog Inputs, both voltage and current is possible.

The configuration of the Multi-serial Module and the components connected to it is also possible through different communication protocols.

In the event of malfunction or breakage, even without power supply, a NFC function enables to download the configuration data, by means of a special App, on an external device to transmit them to a new Multi-serial Module.

The supply includes:
 2 tie-rods

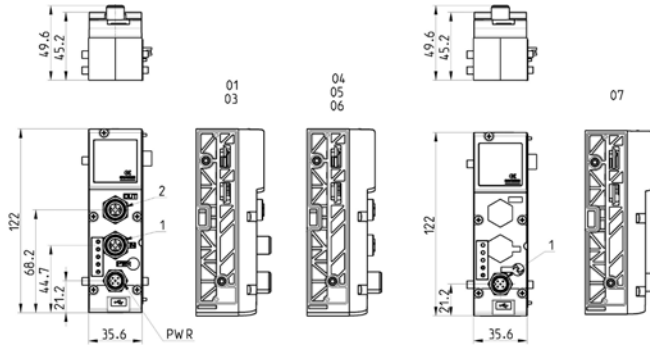

NO WLAN / WITH WLAN	Mod.	Fieldbus Protocol	1	2	Bus-IN connector	Bus-OUT connector
CX4010-0/CX401W-0	01	PROFIBUS	Bus-OUT	Bus-IN	M12 B 5-pin male	M12 B 5-pin female
CX4030-0/CX403W-0	03	CANopen	Bus-OUT	Bus-IN	M12 A 4-pin male	M12 A 4-pin female
CX4040-0/CX404W-0	04	EtherNet/IP	Bus-IN	Bus-OUT	M12 D 4-pin female	M12 D 4-pin female
CX4050-0/CX405W-0	05	EtherCAT	Bus-IN	Bus-OUT	M12 D 4-pin female	M12 D 4-pin female
CX4060-0/CX406W-0	06	PROFINET	Bus-IN	Bus-OUT	M12 D 4-pin female	M12 D 4-pin female
CX4070-0/CX407W-0	07	I/O-link	Bus	-	M12 B 4-pin male	-

Multi-serial modules Cover



It is possible to configure a valve island using only the housing base of the Fieldbus cover, this allows to use the island with different Fieldbus types simply by integrating the relative cover.
 It is not possible to assemble an I/O-link cover on a Fieldbus base or a Fieldbus cover on an I/O-Link base.
 The position of the fixing screws on the front of the cover allows a quick installation or replacement.

The supply includes:
 1 cover
 5 fixing screws

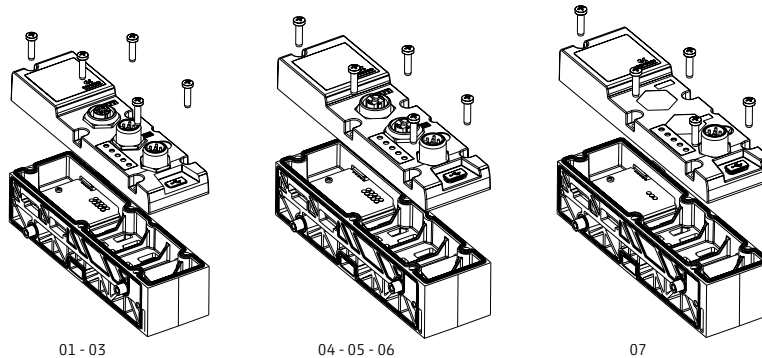

NO WLAN / WITH WLAN	Mod.	Fieldbus Protocol
CX4510-0/CX451W-0	01	PROFIBUS
CX4530-0/CX453W-0	03	CANopen
CX4540-0/CX454W-0	04	EtherNet/IP
CX4550-0/CX455W-0	05	EtherCAT
CX4560-0/CX456W-0	06	PROFINET
CX4570-0/CX457W-0	07	I/O LINK

Digital Input Module Mod. ME4-0800-DC, ME4-0800-DL and ME4-1600-DT



The Digital Input Module can be connected at the left of the Multi-serial module and can be placed in any order with other, both digital and analog Input/Output modules.
The module integrates diagnostic functions and is available in versions with:

- 8 M8 3-pin connectors
- 4 M12 connectors
- Terminal block (Push-in) for the connection of 16 inputs

In the terminal block version, power supply is normally provided by the valve island directly.
In case of loads exceeding 800mA, power supply is provided by an external power supply to be connected to a 2-pin terminal block connector (PWR).

The supply includes:
2 tie-rods

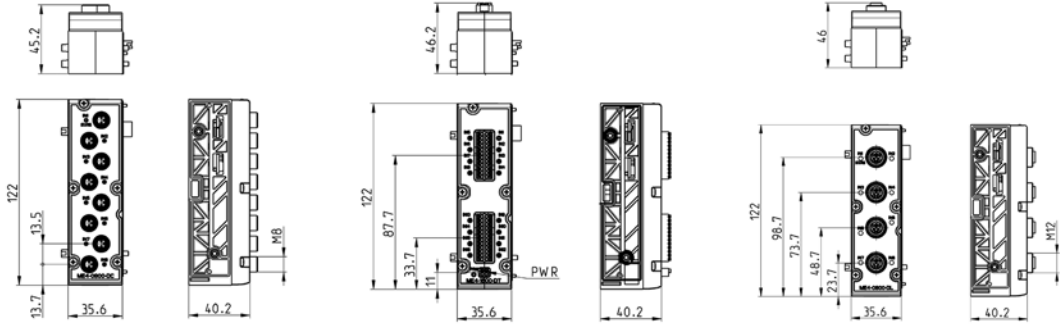

Mod.	Coding reference	Number of digital inputs	Connection	Number of connectors	Dimensions	Signalling	Sensor supply	Overvoltage protection	Absorption	Type of signal	Protection class	Operating temperature	Weight
ME4-0800-DC	A	8	M8 3 pin female	8	122 x 35,6 mm	8 yellow led 1 red led	24 V DC	400 mA for 4 sensors	10 mA	PNP	IP65	0 ÷ 50°C	110 g
ME4-0800-DL	P	8	M12 5 pin female	4	122 x 35,6 mm	4 yellow led 1 red led	24 V DC	400 mA for 4 sensors	10 mA	PNP	IP65	0 ÷ 50°C	110 g
ME4-1600-DT	B	16	2 terminal blocks 24 pin (push-in)	-	122 x 35,6 mm	8 yellow led 1 red led	24 V DC	Internal: 800 mA for 16 sensors External: 2 A for 16 sensors	10 mA	PNP	IP20	0 ÷ 50°C	110 g

Digital Input Module Cover Mod. ME4-0800-DC, ME4-0800-DL and ME4-1600-DT



It is possible to configure a valve island with free electric positions.
You can integrate further electrical signals in a valve island by replacing the cover plate with the relative I/O cover.

The supply includes:
1 cover
5 fixing screws

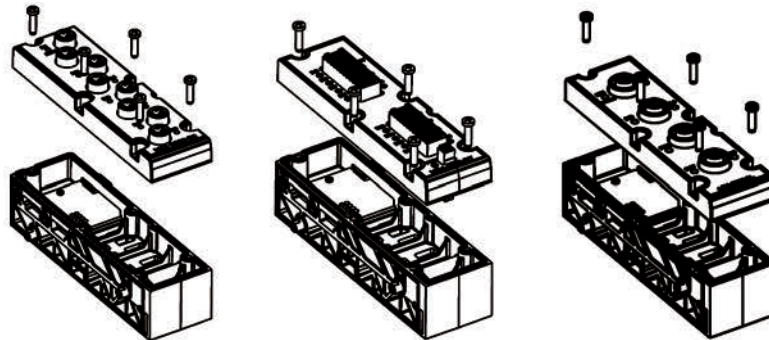

Mod.	Connection
ME4-0800-DC-C	M8 3-pin female
ME4-0800-DL-C	M12 5-pin female
ME4-1600-DT-C	2 terminal blocks 24-pin (Push-in)

Digital Output Module Mod. ME4-0008-DC, ME4-0008-DL and ME4-0016-DT



The Digital Output Module is connected on the left side of the Multi-serial module and can be positioned as desired with other both Digital and Analog I/O devices.

Available in three versions:

- 8 M8 3 pin connectors
- 4 M12 connectors
- (Push-In) Terminal block for the connection of 16 outputs (8+8). The wire connection part is removable from the module.

For all versions, the outputs can be configured as PNP or NPN by means of a software UVIX (the standard version is configured as PNP). The 8 output version can supply 24W and is supplied directly by the valve island. In the terminal block version, the power supply must always be supplied externally with 12-32V voltages, on the 2-pole connector. A maximum absorption of 48 W is possible. The module is equipped with diagnostics (Status).

The supply includes:
2 tie-rods

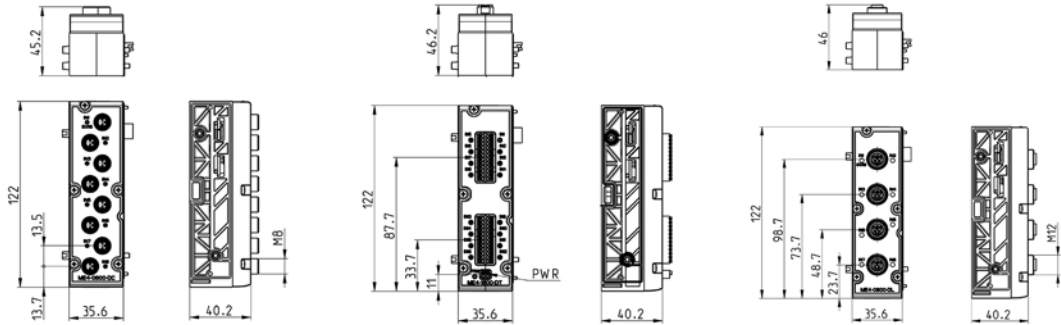

Mod.	Coding reference	N° of digital outputs	Connection	Number of connectors	Dimensions	Signalling	Supply outputs	Max current per module	Max power per digital output	Type of signal	Protection class	Operating temperature	Weight
ME4-0008-DC	Q	8	M8 3-pin female	8	122 x 35,6 mm	8 yellow led 1 red led	24 V DC	24 W	3 W	NPN/ PNP	IP65	0 ÷ 50°C	100 g
ME4-0008-DL	Y	8	M12 5-pin female	4	122 x 35,6 mm	4 yellow led 1 red led	24 V DC	24 W	3 W	NPN/ PNP	IP65	0 ÷ 50°C	100 g
ME4-0016-DT	R	16	2 terminal blocks 24-pin (Push-in)	-	122 x 35,6 mm	8 yellow led 1 red led	12-32 V DC	48 W	3 W	NPN/ PNP	IP20	0 ÷ 50°C	100 g

Digital Output Module Cover Mod. ME4-0008-DC, ME4-0008-DL and ME4-0016-DT



It is possible to configure a valve island with free electric positions. You can integrate further electrical signals in a valve island by replacing the cover plate with the relative I/O cover.

The supply includes:
1 cover
5 fixing screws

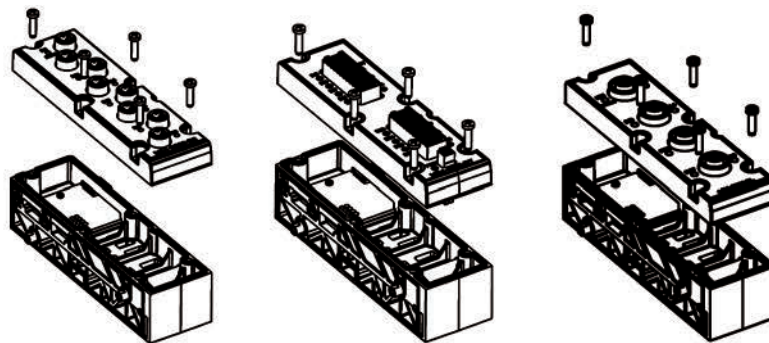

Mod.	Connection
ME4-0008-DC-C	M8 3-pin female
ME4-0008-DL-C	M12 5-pin female
ME4-0016-DT-C	2 terminal blocks 24-pin (Push-in)

Analog Input Module Mod. ME4-C000-AL and ME4-C000-AT



The Analog Input Module can be connected at the left of the CPU module and can be placed in any order with other Input/Output devices.

It is possible to configure every analog input as differential input 0-10V, ±10V, 0-20mA, 4-20mA, ±20mA with a resolution up to 16 bit.

External voltage of 24 V is available to supply the sensor connected (max 0,25A/channel). The output is protected against short-circuit.

The module is equipped with diagnostics (Status) and is available both in the version with two M12 connectors with 5 contacts, and in terminal block version with Push-in spring connection.

The supply includes:
2 tie-rods

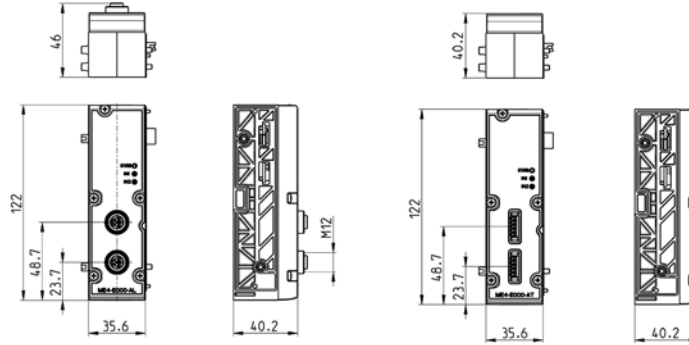

Mod.	Coding reference	Number of analog inputs	Connection	Number of connectors	Dimension	Signalling	Sensor supply	Overvoltage protection	Absorption	Protection class	Operating temperature	Weight
ME4-C000-AL	C	2 (Config. 0-10V,±10V,0-20mA,4-20mA,±20mA)	M12 A 5-pin female	2	122 x 35,6 mm	2 yellow led 1 red led	24 V DC	500 mA shared between the two channels	max 20 mA	IP65	0 ÷ 50°C	110 g
ME4-C000-AT	D	2 (Config. 0-10V,±10V,0-20mA,4-20mA,±20mA)	Terminal block 5-pin (Push-in)	2	122 x 35,6 mm	2 yellow led 1 red led	24 V DC	500 mA shared between the two channels	max 20 mA	IP20	0 ÷ 50°C	110 g

Analog Input Module Cover Mod. ME4-C000-AL and ME4-C000-AT



It is possible to configure a valve island with free electric positions. You can integrate further electrical signals in a valve island by replacing the cover plate with the relative I/O cover.

The supply includes:
1 cover
5 fixing screws

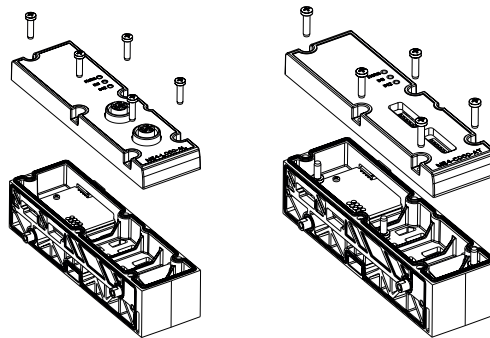

Mod.	Connection
ME4-C000-AL-C	M12 A 5-pin female
ME4-C000-AT-C	Terminal block 5-pin (Push-in)

Analog Output Module Mod. ME4-T000-AL and ME4-T000-AT



The Analog Output Module can be connected at the left of the Multi serial module and can be placed in any order with other Input/Output devices.

It is possible to configure every analog output as 0-10V, 0-5V, 4-20mA, 0-20mA output with a resolution up to 16 bit.

External voltage of 24 V is available to supply the device connected (max 0,25A/channel). The output is protected against short-circuit.

The module is equipped with diagnostics (Status) and is available both in the version with two M12 connectors with 5 contacts, and in terminal block version with Push-in spring connection.

The supply includes:
2 tie-rods

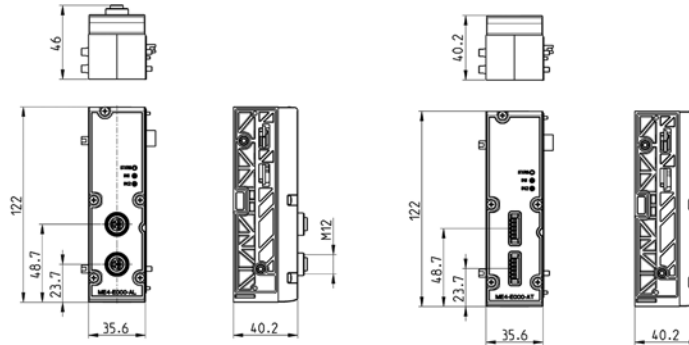

Mod.	Coding reference	Number of analog outputs	Connection	Number of connectors	Dimension	Signalling	Supplied externally	Overvoltage protection	Absorption	Protection class	Operating temperature	Weight
ME4-T000-AL	T	2 (Config. 0-10V,0-5V,0-20mA,4-20mA)	M12 A 5-pin female	2	122 x 35,6 mm	2 yellow led 1 red led	24 V DC	500 mA shared between the two channels	max 6 mA	IP65	0 ÷ 50°C	110 g
ME4-T000-AT	U	2 (Config. 0-10V,0-5V,0-20mA,4-20mA)	Terminal block 5-pin (Push-in)	2	122 x 35,6 mm	2 yellow led 1 red led	24 V DC	500 mA shared between the two channels	max 6 mA	IP20	0 ÷ 50°C	110 g

Analog Output Module Cover Mod. ME4-T000-AL and ME4-T000-AT



It is possible to configure a valve island with free electric positions. You can integrate further electrical signals in a valve island by replacing the cover plate with the relative I/O cover.

The supply includes:
1 cover
5 fixing screws

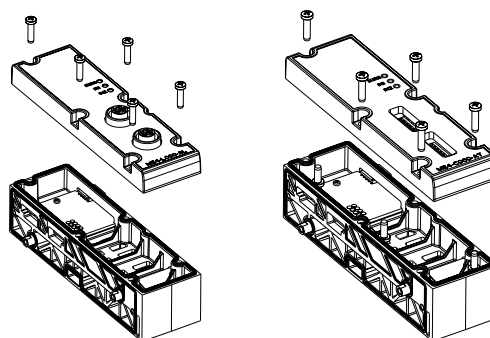

Mod.	Connection
ME4-T000-AL-C	M12 A 5-pin female
ME4-T000-AT-C	Terminal block 5-pin (Push-in)

Analog Input Module Mod. ME4-E000-A*, ME4-G000-A* and ME4-L000-A*



The Analog Input Module can be connected at the left of the CPU module and can be placed in any order with other, both digital and analog Input/Output devices.

Analog, 2-channel Bridge module (ME4-E000-A*):

Sensor data acquisition module with Resistor Bridge-type (4-wire) output, like strain gauge, non isolated.

The module is able to process the two channel inputs with gain factor from 1mV/V to 255mV/V, with a resolution of up to 24bit.

Supply voltage of the sensor +5V (max 0,05A/channel). The output is protected against short-circuit.

Analog, 2-channel RTD module (ME4-G000-A*):

RTD Temperature sensor data acquisition module, in 2/3/4-wire configuration, non isolated.

The module is able to process the following sensor types:

PT100, PT200, PT500, PT1000, Ni100, Ni120, Ni1000, with a resolution of up to 16bit.

Typical measuring fields range from -200 ÷ +850 °C (PT sensors) and -60 ÷ +250 °C (Ni sensors)

Analog, 2-channel TC (thermocouples) module (ME4-L000-A*):

TC temperature sensor data acquisition module in 2-wire configuration, non isolated.

The module is able to process the following sensor types:

J, K, B, E, N, R, S, T, with a resolution of up to 16bit.

All modules are equipped with diagnostics (Status).

The characteristics of the single input can be configured by a software for all analog module types.

The modules are available both in the version with two M12 connectors with 5 contacts, and in the terminal block version with Push-in spring connection.

The supply includes:
2 tie-rods

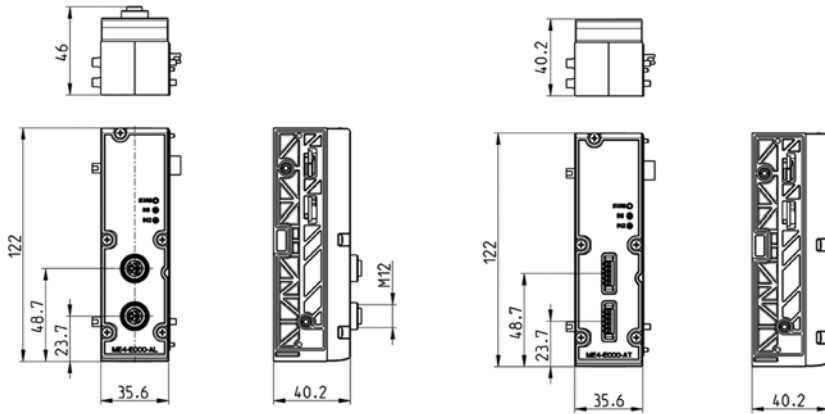

Mod.	Coding reference	Numbers of analog inputs	Connection	Number of connectors	Dimension	Signalling	Absorption	Protection class	Operating temperature	Weight
ME4-E000-AL	E	2 M12 bridge inputs	M12 A 5-pin female	2	122 x 35,6 mm	2 yellow led 1 red led	max 20 mA	IP65	0 ÷ 50°C	110 g
ME4-E000-AT	F	2 bridge inputs with terminal block (Push-in)	Terminal block (Push-in) 5-pin	2	122 x 35,6 mm	2 yellow led 1 red led	max 20 mA	IP20	0 ÷ 50°C	110 g
ME4-G000-AL	G	2 RTD M12 inputs	M12 A 5-pin female	2	122 x 35,6 mm	2 yellow led 1 red led	max 20 mA	IP65	0 ÷ 50°C	110 g
ME4-G000-AT	H	2 RTD inputs with terminal block (Push-in)	Terminal block (Push-in) 5-pin	2	122 x 35,6 mm	2 yellow led 1 red led	max 20 mA	IP20	0 ÷ 50°C	110 g
ME4-L000-AL	L	2 TC M12 inputs	M12 A 5-pin female	2	122 x 35,6 mm	2 yellow led 1 red led	max 20 mA	IP65	0 ÷ 50°C	110 g
ME4-L000-AT	M	2 TC inputs with terminal block (Push-in)	Terminal block (Push-in) 5-pin	2	122 x 35,6 mm	2 yellow led 1 red led	max 20 mA	IP20	0 ÷ 50°C	110 g

Analog Input Module Cover Mod. ME4-E000-A*, ME4-G000-A* and ME4-L000-A*



It is possible to configure a valve island with free electric positions.
You can integrate further electrical signals in a valve island by replacing the cover plate with the relative I/O cover.

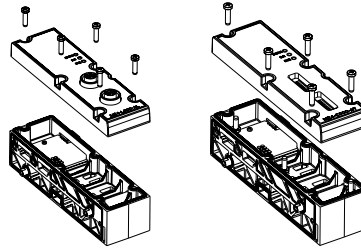

The supply includes:
1 cover
5 fixing screws

Mod.	Connection
ME4-E000-AL-C	M12 A 5-pin female
ME4-E000-AT-C	Terminal block (Push-in) 5-pin
ME4-G000-AL-C	M12 A 5-pin female
ME4-G000-AT-C	Terminal block (Push-in) 5-pin
ME4-L000-AL-C	M12 A 5-pin female
ME4-L000-AT-C	Terminal block (Push-in) 5-pin

Closed base without I/O cover

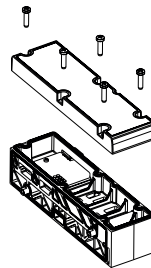

The supply includes:
2 tie-rods

Mod.
ME4-0000-FP

Base without Fieldbus cover

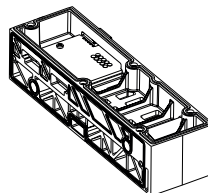

The supply includes:
2 tie-rods

Mod.
CX4000-0

Tie-rods for valve size 4

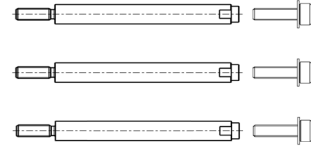

Mod.	Valve positions	NOTE
DA4K-1	-	**
DA4K-2	2	*
DA4K-4	4	*
DA4K-6	6	*
DA4K-8	8	*
DA4K-10	10	*
DA4K-12	12	*
DA4K-14	14	*
DA4K-16	16	*
DA4K-18	18	*
DA4K-20	20	*
...		*
DA4K-64	64	***

* Tie-rod.
The supply includes 3 tie-rods and 3 screws.
** Joint bolt for odd positions.
The supply includes 3 joint bolts.

M12 male terminating resistor

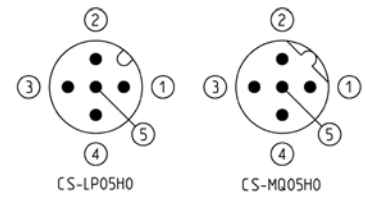
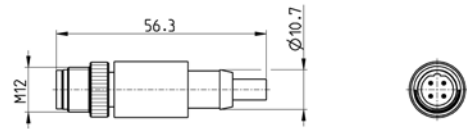

Mod.	description	type of connector	connection	Fieldbus
CS-MQ05H0	moulded terminating resistor	straight	M12 B 4 pin male - Pin 5 is not connected	PROFIBUS
CS-LP05H0	moulded terminating resistor	straight	M12 A 5 pin male - Pin 5 is connected	CANOpen

Straight connector for power supply

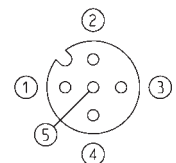
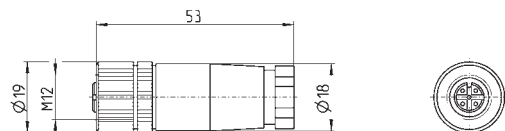

Mod.	description	type of connector	connection	cable length (m)
CS-LF04HB	for wiring	straight	M12 A 4 pin female - Pin 5 is not connected	-

Straight female M12 connectors for Bus-IN

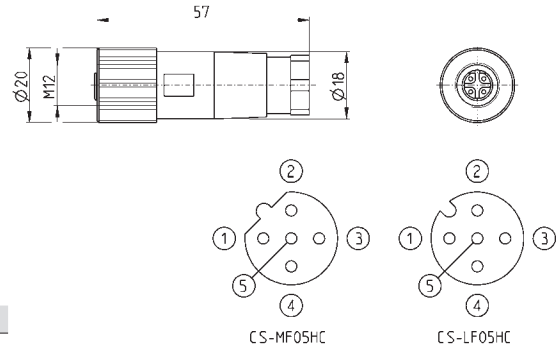

Mod.	description	type of connector	connection	Fieldbus
CS-LF05HC	for wiring	straight	M12 A 5 pin female	CANopen/IQ-Link
CS-MF05HC	for wiring	straight	M12 B 5 pin female	PROFIBUS

Male M12 connectors for Bus-OUT and I/O modules

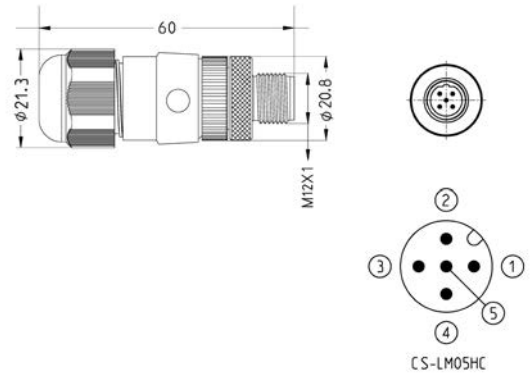

Mod.	description	type of connector	connection	Fieldbus
CS-LM05HC	for metal wiring	straight	M12 A 5 pin male	CANopen

Straight male M12 connectors for Bus-OUT PROFIBUS

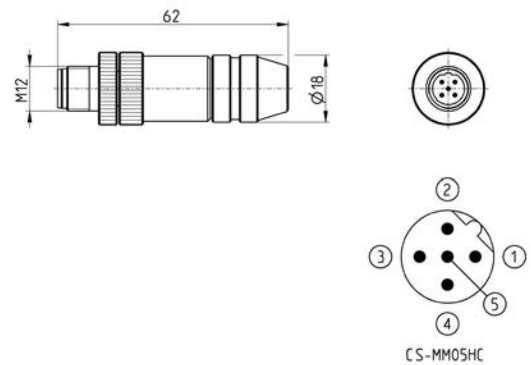

Mod.	description	type of connector	connection	Fieldbus
CS-MM05HC	for metal wiring	straight	M12 B 5 pin male	PROFIBUS

3 pin male M8 wiring connector for digital input modules

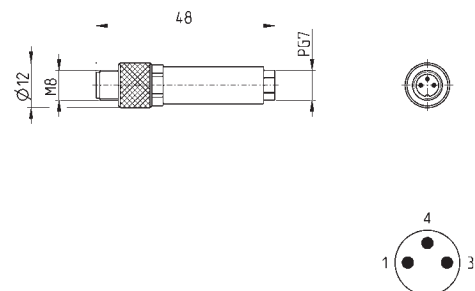

Mod.	description	type of connector	connection	cable length (m)
CS-DM03HB	for wiring	straight	M8 3 pin male	-

Male wiring connector for Bus-IN and Bus-OUT

For PROFINET, EtherCAT, EtherNet/IP

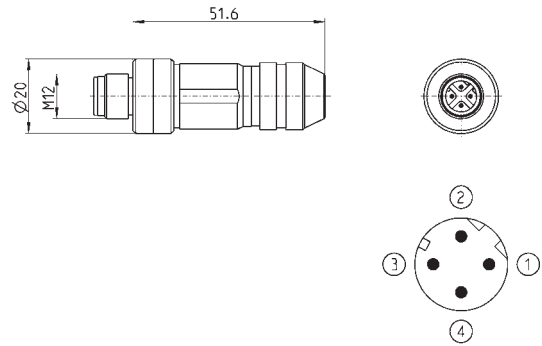

Mod.	description	type of connector	connection	cable length (m)
CS-SM04H0	for metal wiring	straight	M12 D 4 pin	-

Cable with M12 5 pin connector, female, shielded

For IO-Link power supply and signal

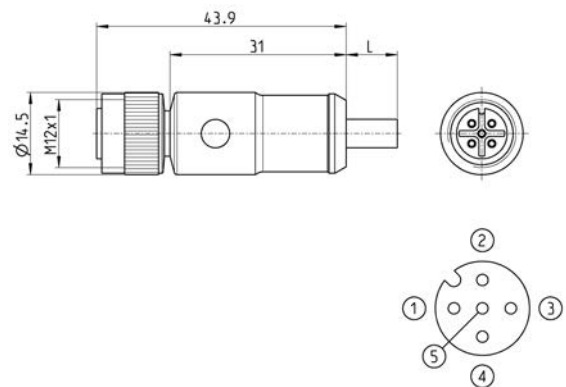

Mod.	Cable length (m)
CS-LF05HB-D200	2
CS-LF05HB-D500	5

Right angle Sub-D female connector 25-44 pins

Protection class IP65

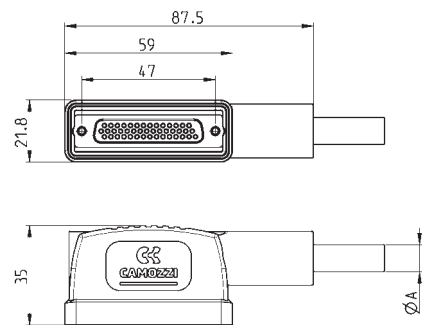

Mod.	A	PIN	cable length (m)
G25X1-3	10	25	3
G25X1-5	10	25	5
G25X1-10	10	25	10
G25X1-15	10	25	15
G25X1-20	10	25	20
G25X1-25	10	25	25
-			
G44X1-3	13	44	3
G44X1-5	13	44	5
G44X1-10	13	44	10
G44X1-15	13	44	15
G44X1-20	13	44	20
G44X1-25	13	44	25

Adaptor and panel mount for Ethernet RJ45 to M12 D networks



For PROFINET, EtherCAT, EtherNet/IP

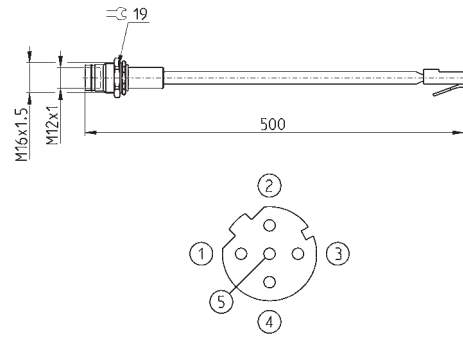

Mod.	description	type of connector	connection	cable length (m)
CS-SE04HB-F050	moulded cable	straight	RJ45 male, M12 D 4 pin female - Pin 5 is not connected	0,5

Extension with M8 connector, 3 pin male / female



Non shielded

For the connection of the digital input modules ME3-0008 and ME3-0004

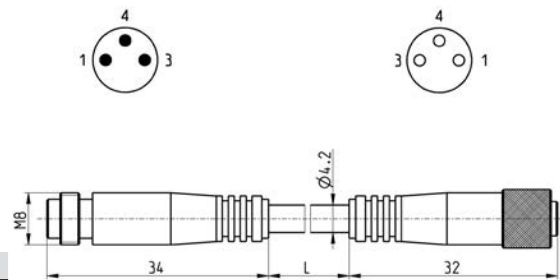

Mod.	description	type of connector	connection	L [cable length] (m)
CS-DW03HB-C250	moulded cable	straight	M8 3 pin male / female	2.5
CS-DW03HB-C500	moulded cable	straight	M8 3 pin male / female	5

USB to Micro USB cable Mod. G11W-G12W-2



For the hardware configuration of the Camozzi products

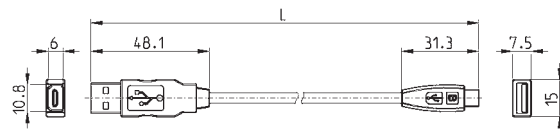

Mod.	description	connections	material for outer sheath	cable length "L" (m)
G11W-G12W-2	black shielded cable 28 AWG	standard USB to Micro USB	PVC	2

Adapter cable, M8 3-pin male - M12 4-pin female



Protection class: IP69K

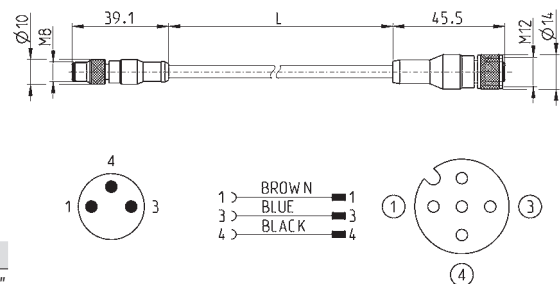

Mod.	description	max voltage	max current	Nr conn. wires	connections	outer sheath	cable "L" (m)
CS-AG03HB-C250	3-pin cable 24 AWG, high flexibility	50V AC / 60V DC	3 A	3	M8 3-pin male - M12 4-pin fem.	PUR black	2.5
CS-AG03HB-C500	3-pin cable 24 AWG, high flexibility	50V AC / 60V DC	3 A	3	M8 3-pin male - M12 4-pin fem.	PUR black	5

Cables with straight connectors



For PROFINET, EtherCAT, EtherNet/IP

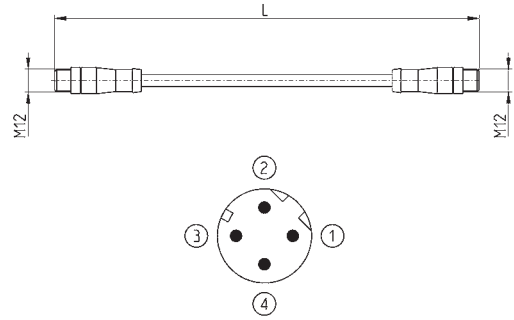

Mod.	description	type of connector	connection	L [cable length] (m)
CS-SB04HB-D100	moulded cable	straight	2x M12 D 4 pin male	1
CS-SB04HB-D500	moulded cable	straight	2x M12 D 4 pin male	5
CS-SB04HB-DA00	moulded cable	straight	2x M12 D 4 pin male	10
CS-SB04HB-DD00	moulded cable	straight	2x M12 D 4 pin male	15
CS-SB04HB-DG00	moulded cable	straight	2x M12 D 4 pin male	20
CS-SB04HB-DJ00	moulded cable	straight	2x M12 D 4 pin male	25

M8 and M12 connector cover caps



For digital and analog input/output modules and subnet

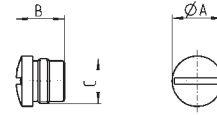

Mod.	A	B	C [Connection]
CS-DFTP	10	11	M8
CS-LFTP	13.5	13	M12

Identification plates



The supply includes:
45 identification plates 9x5mm

Mod.
HP1/E

Mounting brackets for DIN rail



DIN EN 50022 (mm 7,5 x 35 - width 1)

The supply includes:
2 plates
2 screws M4x6 UNI 5931

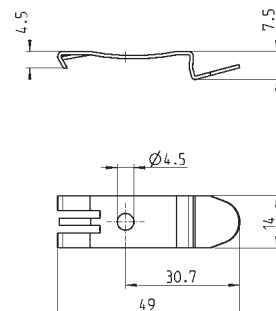

Mod.
PCF-E520

Silencers Series 2931

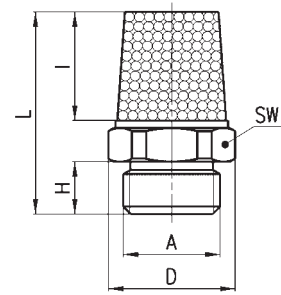

SIL 1



DIMENSIONS									
Mod.	A	D	H	I	L	SW	Max. Oper. Pressure	Flow rate NI/Min	Noise db (A)
2931 1/8	G1/8	13	4,5	13	21	12	10	1927	88
2931 3/8	G3/8	20	7	23	35,5	19	10	4560	81
2931 1/2	G1/2	24,5	8	28	42	23	10	6800	87