

**VALVE ISLAND WITH
COILVISION® TECHNOLOGY
SERIES D**

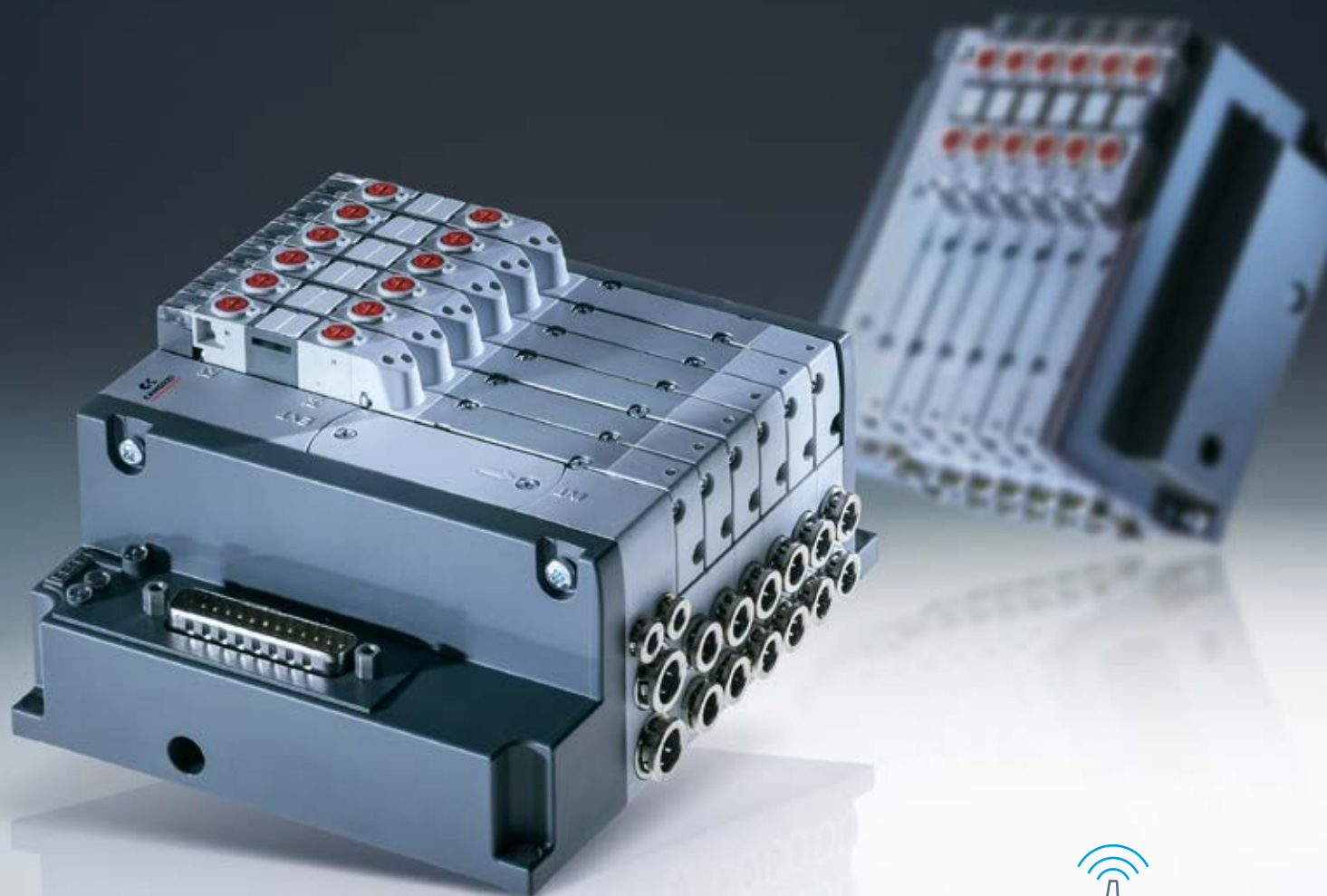

SERIES D MODULAR AND FLEXIBLE

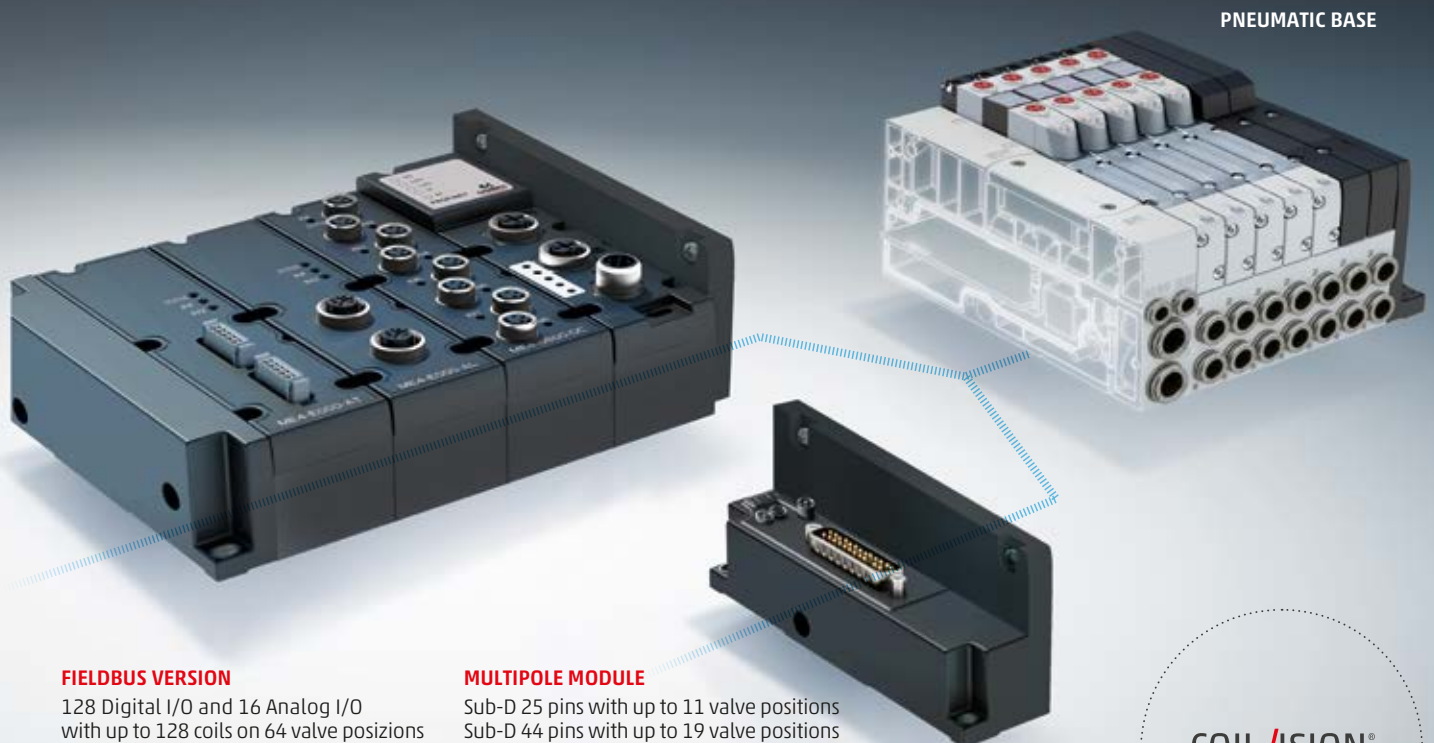

PNEUMATIC BASE

FIELDBUS VERSION

128 Digital I/O and 16 Analog I/O
with up to 128 coils on 64 valve positions

IO-LINK VERSION

64 coils on 32 valve positions

MULTIPOLE MODULE

Sub-D 25 pins with up to 11 valve positions
Sub-D 44 pins with up to 19 valve positions



Series D is a new valve system that ensures maximum flexibility and productivity across many primary industrial automation processes.

Single pneumatic and electric subbases plus a simple valve-connection system make the valve island Series D the ideal solution for all applications that require quick and easy installation of pneumatic functionality.

Series D is available in both multipole and in serial communication versions. The Fieldbus module allows control of the valve island using the main fieldbus protocols, making it easy to integrate pneumatic and electrical functionality in the most advanced automation systems.

The valve island Series D also equipped with **CoilVision® technology** which can monitor and predict the wear and efficiency status of selected parts of the solenoid valves. The gathered data, alarm history and health status are indicated through different combinations of flashing LEDs on the module and can be sent to a PLC or to a wireless IIoT gateway and then on to the Cloud.

BENEFITS



Flexibility of valve connection I/O modules



Integrated diagnostics and predictive capability



**Available protocols:
PROFIBUS-DP, CANopen, EtherNet/IP,
PROFINET, EtherCAT, IO-Link**



**UL Recognized Component
for Canada and the United States**

SERIES D

4 SIZES FOR UNLIMITED APPLICATIONS

Series D - Size 1



Ideal solution for all industrial applications that require quick and easy installation of pneumatic functionality in restricted spaces.

TECHNICAL CHARACTERISTICS

- Size 10.5 mm
- Flow 250 NL/min



Compact design



Individual, modular sub-bases in technopolymer



Highly expandable electric and pneumatic functionality

Series D - Size 2



This valve island is designed for applications that demand compact dimensions and high flow rates.

TECHNICAL CHARACTERISTICS

- Size 16 mm
- Flow 950 NL/min



Compact design



Individual, modular sub-bases in technopolymer



Highly expandable electric and pneumatic functionality

Series D - Size 4



Particularly suitable for all applications that require high flow rates and require solutions with a robust and compact design.

TECHNICAL CHARACTERISTICS

- Size 25 mm
- Flow 2000 NL/min



High flow rates



Robust design



High reliability

Series D - Size 5



A single island with a mix of sizes (10.5 and 16) that offers one Multipole or Fieldbus connection, with common positional fixings and single modularity.

TECHNICAL CHARACTERISTICS

- Size 10.5 + 16 mm
- Flow 250 - 950 NL/min



Only one connection (Multipole or Fieldbus)



Combination of flow types in one valve island



Compact dimensions

The serial module enables control of the valve island Series D with the most common fieldbus protocols, making it easier to integrate pneumatic and electric functions in the most advanced automation systems.

Every communication protocol has its own peculiarities. In case of replacing the fieldbus, it will not be necessary to redesign the space in which the island is located as the CX4 module maintains the same dimensions.

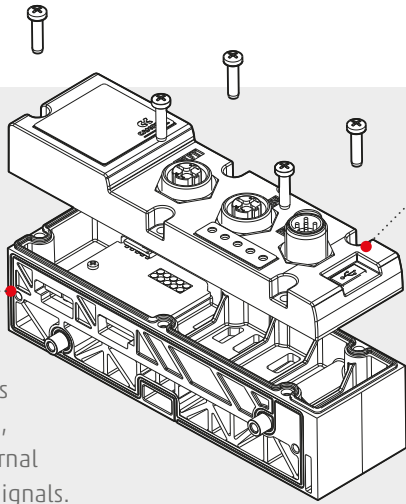

BASE:
The same for all fieldbus nodes and I/O modules, it carries the internal communication signals.

COVER:
Contains the interface electronics towards the external network.



Each module is composed of two separate elements, base and cover, that simplify assembly and replacement of the node, without the need to disassemble the entire island.

The electrical terminal can be easily connected to the island by means of tie-rods, that maintain the overall dimensions of the system contained.

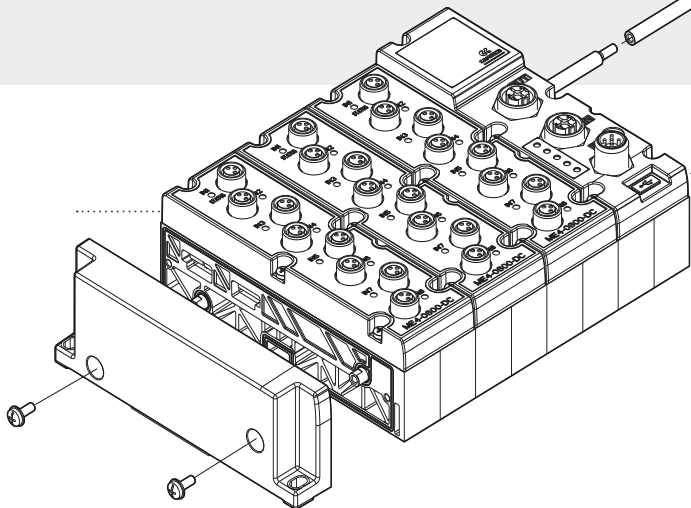
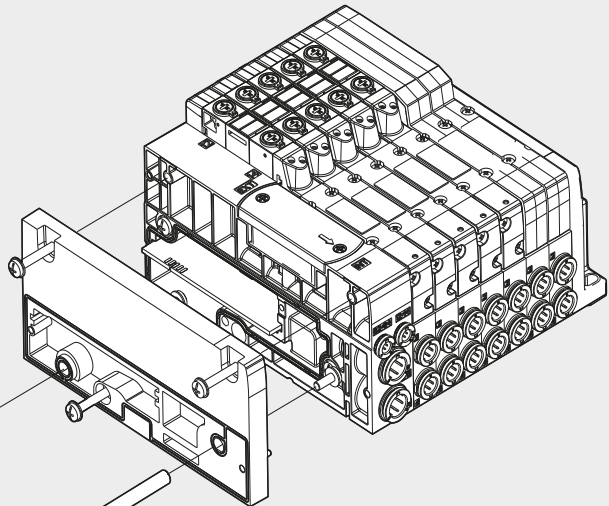

As well as different analog and digital I/O modules, advanced modules can be connected to the serial module to acquire data from thermocouples, RTD temperature sensors or sensors in bridge configuration. The mechanical and electrical connection system and the internal bus allow for extreme flexibility, so you are free to add, move, remove and replace different modules as well as replace its communication protocol. All this in restricted spaces.

Series D - General data

PNEUMATIC SECTION	Size 1	Size 2	Size 4	Size 5
Valve construction	spool with seals			
Valve functions	5/2 monostable and bistable 5/3 CC; CP; CO 2 x 3/2 NC 2 x 3/2 NO 1 x 3/2 NC + 1 x 3/2 NO			
Materials	spool and body: AL spool seals: HNBR other seals: NBR end caps, subbase: polymer Individual subbase (Size 4): AL			
Connections				
Threads	M7	G1/4"	G3/8"	
Cartridges subbase	∅ 4; ∅ 6	∅ 6; ∅ 8; ∅ 10		∅ 4 ÷ ∅ 10
Temperature	0 ÷ 50 °C			
Air characteristics	compressed, filtered and non-lubricated air in class 7.4.4 according to ISO 8573-1:2010. In case lubrication should be necessary, only use oils with a maximum viscosity of 32 Cst and the version with external servo-pilot supply. The air quality of the servo-pilot supply must be of class 7.4.4 according to ISO 8573-1:2010 (do not lubricate).			
Valve sizes	10.5 mm	16 mm	25 mm	10.5 + 16 mm
Operating pressure	-0.9 ÷ 10 bar			
Pilot pressure	2.5 ÷ 7 bar 4,5 ÷ 7 bar (with operating pressure exceeding 6 bar for the version 2x3/2)			
Flow rate	250 NL/min	950 NL/min	2000 NL/min	250 / 950 NL/min
Mounting position	any position			
Protection class	IP65			

ELECTRICAL SECTION - MULTIPOLE VERSION

Type of Sub-D connector	25 or 44 pins			
Max. absorption	0.8 A (with Sub-D connector 25 pins) 1 A (with Sub-D connector 44 pins)			
Supply voltage	24 V DC +/-10%			
Max. num. of coils to operate	22 on 11 valve positions (with Sub-D connector 25 pins) 38 on 19 valve positions (with Sub-D connector 44 pins)			
Signalling LED	Green LED - presence of power Red LED - anomaly Valve: yellow LED - presence of power blinking yellow LED - operating fault			

ELECTRICAL SECTION - FIELDBUS VERSION

Available protocols	PROFIBUS-DP, CANopen, EtherNet/IP, PROFINET, EtherCAT			
Max. absorption	2.5 A			
Supply voltage	24 V DC +/-10% logic supply 24 V DC +/-10% power supply			
Max. num. of coils to operate	128 on 64 valve positions			
Max. num. of digital inputs	128			
Max. num. of analog inputs	16			
Max. num. of digital outputs	128			
Max. num. of analog outputs	16			

IO-LINK VERSION







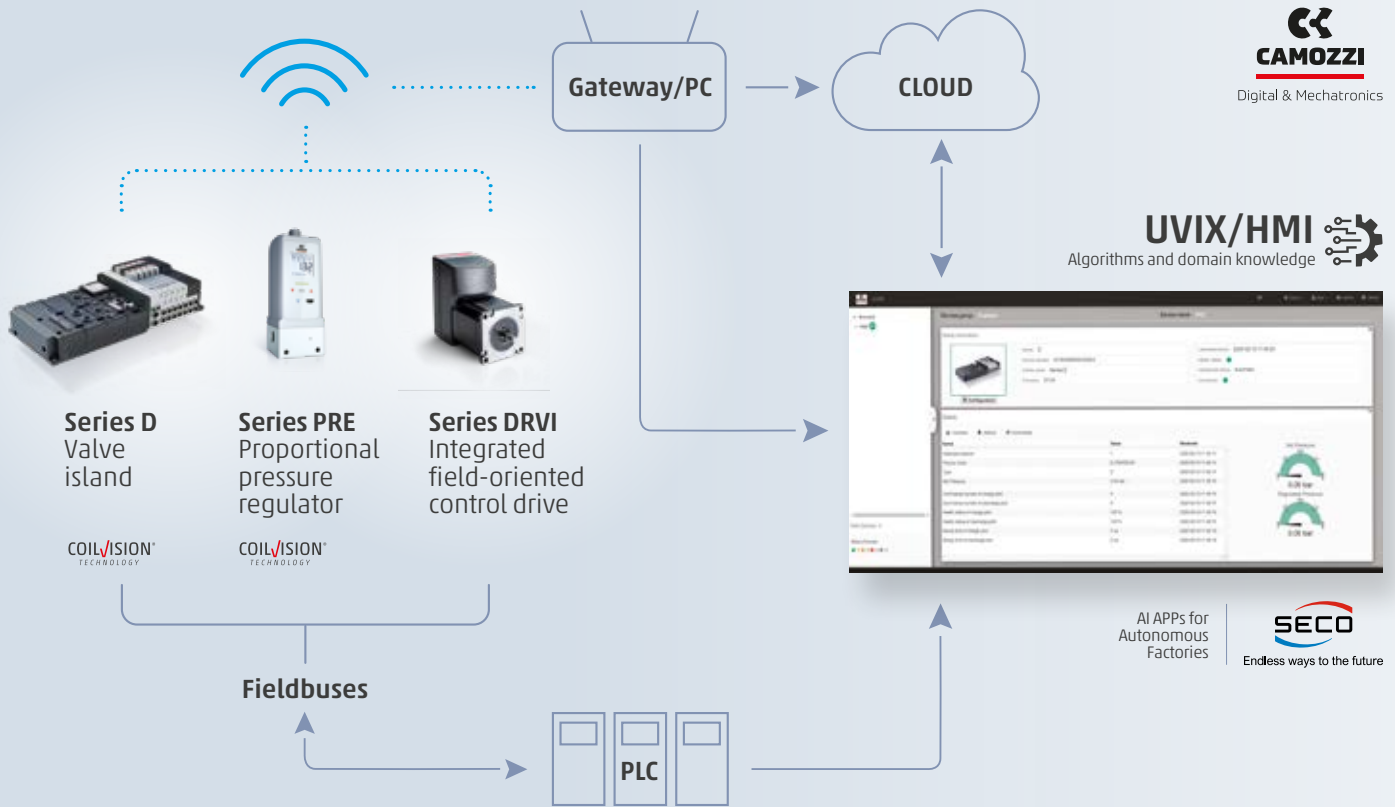

Max num. of coils to operate	64 on 32 valve positions			
Input and Output	No			
Type of port	Class B			
IODD Configuration file	up to 12, 24 or 32 valve positions per island			

(The IO-Link module on the valve island configuration itself to work with the correct IODD)

COILVISION® DIAGNOSTICS



DIAGNOSTIC CHARACTERISTICS

	ON/OFF status of each valve		Interrupted solenoid
	Health status		Over and under voltage
	Short circuit or solenoid fault		Cycle counter
	Temperature monitoring of the Master module and the solenoids		Power consumption



COILVISION®
TECHNOLOGY

CoilVision® technology has been developed to constantly monitor the operating parameters of the solenoid that drives the spool. Each operation of the solenoid, in different cyclic configurations and environmental conditions, is analysed to acquire information that is processed by software algorithms to diagnose and predict the health status of the component.

Contacto:
Esperia, S.A.
Arangutxi, 13.-Pol.Ind. de Júndiz
01015 Vitoria.-
Tel. +34 945 290105
comercial@esperia.es



Automation